

A Cubical Set Approach to 2-Bundles with Connection and Wilson Surfaces

João Faria Martins

Departamento de Matemática

Faculdade de Ciências e Tecnologia, Universidade Nova de Lisboa

Quinta da Torre, 2829-516 Caparica, Portugal

jn.martins@fct.unl.pt

Roger Picken

Departamento de Matemática,

Instituto Superior Técnico, TU Lisbon

Av. Rovisco Pais, 1049-001 Lisboa, Portugal

rpicken@math.ist.utl.pt

October 25, 2010

Abstract

In the context of non-abelian gerbes we define a cubical version of categorical group 2-bundles with connection over a smooth manifold. We define their two-dimensional parallel transport, study its properties, and define non-abelian Wilson surface functionals.

Keywords cubical set; non-abelian gerbe; 2-bundle; 2-dimensional holonomy; non-abelian integral calculus; categorical group; double groupoid; Higher Gauge Theory; Wilson surface.

2000 Mathematics Subject Classification: 53C29 (primary); 18D05, 70S15 (secondary)

1 Introduction

The aim of this paper is to address the differential geometry of (categorical group) 2-bundles over a smooth manifold M and their two dimensional parallel transport with a minimal use of two dimensional category theory, the ultimate goal being to define Wilson surface observables. The only categorical notion needed is that of an (edge symmetric, strict) double groupoid (with thin structure), which is equivalent to a crossed module or to a categorical group; see [BH1, BHS, BH6, BL, BS, BM]. We also use the concept of a cubical set

[BH2, J1, GM], a cubical analogue of a simplicial set, familiar in algebraic topology; see for example [Ma].

Our definition of a 2-bundle with connection will be given in the framework of cubical sets. Given a crossed module of Lie groups $\mathcal{G} = (\partial: E \rightarrow G, \triangleright)$, where \triangleright is a left action of G on E by automorphisms, the definition of a cubical \mathcal{G} -2-bundle with connection \mathcal{B} over a manifold M is an almost exact cubical analogue of the simplicial version considered in [H, BS1, BS2, BrMe]. Following [H, MP], we will consider a coordinate neighbourhood description of 2-bundles with connection. For a discussion of the *total space* of a 2-bundle see [RS, Bar, Wo].

We also define the thin homotopy double groupoid of a smooth manifold M , constructed from smooth maps from the square to M , identified modulo thin homotopy. An advantage of the cubical setting over the simplicial setting is that subdivision is very easy to understand. In a cubical \mathcal{G} -2-bundle with connection, all connection forms are in principle only locally defined. Therefore, given a smooth map $[0, 1]^2 \rightarrow M$, to define its holonomy (for brevity we will use the term holonomy, instead of the more accurate term, parallel transport), one needs to subdivide $[0, 1]^2$ into smaller squares, consider all the locally defined holonomies (which we will define and analyse carefully) and patch it all together by using the 1- and 2-transition functions of the cubical \mathcal{G} -2-bundle, and the transition data of the connection. A double groupoid provides a convenient context for doing this type of calculations, and is easier to handle than the decomposition of $[0, 1]^2$ into regions by means of a trivalent embedded graph of [P]. Citing [BHS, BH1], double groupoids trivially have an algebraic inverse to subdivision. This was the motivation for our cubical set approach to 2-bundles with connection and their holonomy.

We derive the local two-dimensional holonomy (based on a crossed module), the transition functions and their properties by extending results from our previous study [FMP1] of holonomy and categorical holonomy in a principal fibre bundle. Even though its definition is apparently non-symmetric in the two variables parametrising $[0, 1]^2$, the local 2-dimensional holonomy which is associated to maps $[0, 1]^2 \rightarrow M$ is covariant with respect to the dihedral group of symmetries of the square. This important result (the Non-Abelian Fubini's Theorem) ultimately follows from the crossed module rules, and would not hold if a pre-crossed module were used.

Let $\mathcal{G} = (\partial: E \rightarrow G, \triangleright)$ be a Lie crossed module. We show (in the final section) that the cubical \mathcal{G} -2-bundle holonomy which we define can be associated to oriented embedded 2-spheres $\Sigma \subset M$ yielding an element $\mathcal{W}(\mathcal{B}, \Sigma) \in \ker \partial \subset E$ (the Wilson sphere observable) independent of the parametrisation of the sphere and the chosen coordinate neighbourhoods, up to acting by elements of G . This follows from the invariance of cubical \mathcal{G} -2-bundle holonomy under thin homotopy (up to acting by elements of G) and the fact that the mapping class group of the sphere S^2 is $\{\pm 1\}$. This Wilson sphere observable depends only on the equivalence class of the cubical \mathcal{G} -2-bundle with connection \mathcal{B} . For surfaces other than the sphere embedded in M , a holonomy can still be defined but it will a priori (since the mapping class group is more complicated) depend on the isotopy type of the parametrisation. We will illustrate this point with the case

of Wilson tori.

An important problem that follows on from this construction is the definition of a gauge invariant action in the space of all 2-bundles with connection over a smooth closed 4-dimensional manifold, analogous to the Chern-Simons action for principal bundles with connection over a 3-dimensional closed manifold - see [B]. Given that a gauge invariant sphere holonomy was defined, this would permit a physical definition of invariants of knotted spheres in S^4 analogue to the Jones polynomial; see for example [W, Ko, AF, CR].

Contents

1	Introduction	1
2	Preliminaries	4
2.1	The Box Category and cubical sets	4
2.1.1	Cubical sets	4
2.2	Lie crossed modules	6
2.2.1	The edge symmetric double groupoid $\mathcal{D}(\mathcal{G})$ where \mathcal{G} is a crossed module	7
2.2.2	Flat \mathcal{G} -colourings, the edge symmetric triple groupoid $\mathcal{T}(\mathcal{G})$ and the nerve $\mathcal{N}(\mathcal{G})$ of the crossed module \mathcal{G}	10
2.3	Construction of the thin homotopy double groupoid of a smooth manifold	11
2.3.1	1-paths, 2-paths and 1-tracks	12
2.3.2	2-Tracks	13
2.3.3	Horizontal and vertical compositions of 2-tracks	14
2.4	Connections and categorical connections in principal fibre bundles	15
2.4.1	Differential crossed module valued forms	15
2.4.2	Categorical connections in principal fibre bundles	15
2.4.3	The categorical curvature 3-form of a \mathcal{G} -categorical con- nection	16
2.4.4	Local form	17
2.5	Holonomy and categorical holonomy in a principal fibre bundle .	17
2.5.1	A form of the Ambrose-Singer Theorem	18
2.5.2	Categorical holonomy in a principal fibre bundle	19
2.5.3	The Non-Abelian Fubini's Theorem	22
2.6	Dependence of the categorical holonomy on a smooth family of squares	23
2.6.1	A well-known lemma	24
2.6.2	The relation between 2-curvature and categorical holonomy	24
2.6.3	Invariance under thin homotopy	31
2.6.4	A (dihedral) double groupoid map	31

3	Cubical \mathcal{G}-2-bundles with connection	32
3.1	Definition of a cubical \mathcal{G} -2-bundle	32
3.2	Connections in cubical \mathcal{G} -2-bundles	34
4	Non-abelian integral calculus based on a crossed module	35
4.1	Path-ordered exponential and surface-ordered exponential	35
4.2	1-Gauge transformations	37
4.2.1	The group of 1-gauge transformations	39
4.2.2	The coherence law for 1-gauge transformations	39
4.2.3	Dihedral symmetry for 1-gauge transformations	41
4.3	Equivalence of cubical \mathcal{G} -2-bundles with connection	41
4.3.1	A crossed module of groupoids of gauge transformations	42
4.3.2	Equivalence of cubical \mathcal{G} -2-bundles with connection over a pair (M, \mathcal{U})	43
4.3.3	Subdivisions of covers and the equivalence of cubical \mathcal{G} - bundles over a manifold	45
4.4	Coherence law for transition 2-cubes	46
5	Wilson spheres and tori	47
5.1	Holonomy for an arbitrary 2-path in a smooth manifold	47
5.1.1	Patching together local holonomies and transition functions	47
5.1.2	Independence under <i>subdividing</i> partitions	48
5.1.3	The case of paths	49
5.1.4	The dependence of the holonomy on the partition \mathcal{Q}	50
5.1.5	Invariance under (free) thin homotopy	51
5.1.6	Dihedral symmetry for the holonomy of general squares	52
5.1.7	Dependence of the surface holonomy on the cubical \mathcal{G} - bundle with connection equivalence class	53
5.2	Two types of Wilson surfaces	54

2 Preliminaries

2.1 The Box Category and cubical sets

2.1.1 Cubical sets

The box category \mathcal{B} , see [J1, BH2, BH3, BHS, GM], is defined as the category whose set of objects is the set of standard n -cubes $D^n \doteq I^n$, where $I \doteq [0, 1]$, and whose set of morphisms is the set of maps generated by the cellular maps $\delta_{i,n}^\pm : D^n \rightarrow D^{n+1}$, where $i = 1, \dots, n+1$ and $\sigma_{i,n} : D^{n+1} \rightarrow D^n$, $i = 1, \dots, n+1$. We have put:

$$\delta_{i,n}^-(x_1, \dots, x_{i-1}, x_{i+1}, \dots, x_n) = (x_1, \dots, x_{i-1}, 0, x_{i+1}, \dots, x_n)$$

$$\delta_{i,n}^+(x_1, \dots, x_{i-1}, x_{i+1}, \dots, x_n) = (x_1, \dots, x_{i-1}, 1, x_{i+1}, \dots, x_n)$$

$$\sigma_{i,n+1}(x_1, \dots, x_{n+1}) = (x_1, \dots, x_{i-1}, x_{i+1}, \dots, x_n).$$

We will usually abbreviate $\delta_{i,n} = \delta_i$ and $\sigma_{i,n} = \sigma_i$.

Definition 2.1 (Cubical set) *A cubical object K in the category of sets (abbrev. “cubical set”) is a functor $\mathcal{B}^{\text{op}} \rightarrow \text{Sets}$, the category of sets; see [BH3, J1, GM, BHS]. Here \mathcal{B}^{op} is the opposite category of the box category \mathcal{B} . A morphism of cubical sets (a cubical map) is a natural transformation of functors. We can analogously define cubical objects in any category, for example in the category of smooth manifolds and their smooth maps (defining cubical manifolds), or more generally in the category of smooth spaces [BHo, Ch].*

Unpacking this definition, we can see that a cubical set K is defined as being an assignment of a set K_n (the set of n -cubes) to each $n \in \mathbb{N}$, together with face maps $\partial_i^\pm: K_n \rightarrow K_{n-1}$ and degeneracy maps $\epsilon_i: K_{n-1} \rightarrow K_n$, where $i \in \{1, \dots, n\}$ satisfying the cubical relations:

$$\begin{aligned} \partial_i^\alpha \partial_j^\beta &= \partial_{j-1}^\beta \partial_i^\alpha & (i < j) \\ \epsilon_i \epsilon_j &= \epsilon_{j+1} \epsilon_i & (i \leq j) \end{aligned} \quad \partial_i^\alpha \epsilon_j = \begin{cases} \epsilon_{j-1} \partial_i^\alpha & (i < j) \\ \epsilon_j \partial_{i-1}^\alpha & (i > j) \\ \text{id} & (i = j) \end{cases} \quad (2.1)$$

Here $\alpha, \beta \in \{-, +\}$. The description of a cubical manifold is analogous, but each K_n is to be a smooth manifold, and all faces and degeneracies are to be smooth. A degenerate cube is a cube in the image of some degeneracy map. A cubical set K for which K_i consists only of degenerate cubes if $i > n$ will be called n -truncated.

Definition 2.2 (Dihedral cubical set) *If a cubical set K has an action of the group of symmetries of the n -cube (the n -hyperoctahedral group) in each set K_n , compatible with the faces and degeneracies in the obvious way, it will be called a dihedral cubical set. A cubical map $K \rightarrow K'$ between dihedral cubical sets that preserves the actions will be called a dihedral cubical map.*

Dihedral cubical sets are called cubical sets with reversions and interchanges in [GM]. To relate the two definitions, note that the n -hyperoctahedral group is generated by reflections and interchanges of coordinates, and is therefore isomorphic to $\mathbb{Z}_2^n \rtimes S_n$.

Example 2.3 *Let M be a manifold. The smooth singular cubical set $C(M)$ of M is given by all smooth maps $D^n \rightarrow M$, where $D^n = [0, 1]^n$ is the n -cube, with the obvious faces and degeneracies, [BH3, BH3]. This is a dihedral cubical set in the obvious way. We can also see $C(M)$ as being a cubical object in the category of smooth spaces [BHo], by giving the set of n -cubes the smooth structure of [Ch, BHo].*

Example 2.4 Analogously, given a smooth manifold M , the restricted smooth singular cubical set $C_r(M)$ of M is given by all smooth maps $f: D^n \rightarrow M$ for which there exists an $\epsilon > 0$ such that $f(x_1, x_2, \dots, x_n) = f(0, x_2, \dots, x_n)$ if $x_1 \leq \epsilon$, and analogously for any other face of D^n , of any dimension. We will abbreviate this condition by saying that f has a product structure close to the boundary of the n -cube. This condition allows the composition of n -cubes to be defined, which we will be needing shortly. In the terminology of [BH3], this example is a cubical set with connections and compositions.

2.2 Lie crossed modules

All Lie groups and Lie algebras are taken to be finite-dimensional. For details on (Lie) crossed modules see, for example, [B1, BM, FM, FMP1, B, BL], and references therein.

Definition 2.5 (Crossed module and Lie crossed module) A crossed module (of groups) $\mathcal{G} = (\partial: E \rightarrow G, \triangleright)$ is given by a group morphism $\partial: E \rightarrow G$ together with a left action \triangleright of G on E by automorphisms, such that:

1. $\partial(g \triangleright e) = g\partial(e)g^{-1}$; for each $g \in G$, for each $e \in E$,
2. $\partial(e) \triangleright f = e f e^{-1}$; for each $e, f \in E$.

If both G and E are Lie groups, $\partial: E \rightarrow G$ is a smooth morphism, and the left action of G on E is smooth then \mathcal{G} will be called a Lie crossed module.

A morphism $\mathcal{G} \rightarrow \mathcal{G}'$ between the Lie crossed modules $\mathcal{G} = (\partial: E \rightarrow G, \triangleright)$ and $\mathcal{G}' = (\partial': E' \rightarrow G', \triangleright')$ is given by a pair of smooth morphisms $\phi: G \rightarrow G'$ and $\psi: E \rightarrow E'$ making the diagram:

$$\begin{array}{ccc} E & \xrightarrow{\partial} & G \\ \psi \downarrow & & \downarrow \phi \\ E' & \xrightarrow{\partial'} & G' \end{array}$$

commutative. In addition we must have $\psi(g \triangleright e) = \phi(g) \triangleright' \psi(e)$ for each $e \in E$ and each $g \in G$.

Given a Lie crossed module $\mathcal{G} = (\partial: E \rightarrow G, \triangleright)$, then the induced Lie algebra map $\partial: \mathfrak{e} \rightarrow \mathfrak{g}$, together with the derived action of \mathfrak{g} on \mathfrak{e} (also denoted by \triangleright) is a differential crossed module, in the sense of the following definition - see [BS1, BS2, B, BC].

Definition 2.6 (Differential crossed module) A differential crossed module (or crossed module of Lie algebras) $\mathfrak{G} = (\partial: \mathfrak{e} \rightarrow \mathfrak{g}, \triangleright)$, is given by a Lie algebra morphism $\partial: \mathfrak{e} \rightarrow \mathfrak{g}$ together with a left action of \mathfrak{g} on the underlying vector space of \mathfrak{e} , such that:

1. For any $X \in \mathfrak{g}$ the map $v \in \mathfrak{e} \mapsto X \triangleright v \in \mathfrak{e}$ is a derivation of \mathfrak{e} , in other words

$$X \triangleright [u, v] = [X \triangleright u, v] + [u, X \triangleright v]; \text{ for each } X \in \mathfrak{g}, \text{ for each } u, v \in \mathfrak{e}.$$

2. The map $\mathfrak{g} \rightarrow \text{Der}(\mathfrak{e})$ from \mathfrak{g} into the derivation algebra of \mathfrak{e} induced by the action of \mathfrak{g} on \mathfrak{e} is a Lie algebra morphism. In other words:

$$[X, Y] \triangleright v = X \triangleright (Y \triangleright v) - Y \triangleright (X \triangleright v); \text{ for each } X, Y \in \mathfrak{g}, \text{ for each } v \in \mathfrak{e}.$$

3. $\partial(X \triangleright v) = [X, \partial(v)]$; for each $X \in \mathfrak{g}$, for each $v \in \mathfrak{e}$.

4. $\partial(u) \triangleright v = [u, v]$; for each $u, v \in \mathfrak{e}$.

Note that the map $(X, v) \in \mathfrak{g} \times \mathfrak{e} \mapsto X \triangleright v \in \mathfrak{e}$ is necessarily bilinear.

A very useful identity satisfied in any differential crossed module is the following:

$$\partial(u) \triangleright v = [u, v] = -[v, u] = -\partial(v) \triangleright u, \text{ for each } u, v \in \mathfrak{e}. \quad (2.2)$$

This will be used several times in this paper.

Given a Lie crossed module $\mathcal{G} = (\partial: E \rightarrow G, \triangleright)$, we will also denote the induced action of G on \mathfrak{e} by \triangleright . Finally, given a differential crossed module, $\mathfrak{G} = (\partial: \mathfrak{e} \rightarrow \mathfrak{g}, \triangleright)$ there exists a unique crossed module of simply connected Lie groups $\mathcal{G} = (\partial: E \rightarrow G, \triangleright)$ whose differential form is \mathfrak{G} , up to isomorphism. The proof of this result is standard Lie theory, together with the lift of the Lie algebra action to a Lie group action, which can be found in [K], Theorem 1.102.

2.2.1 The edge symmetric double groupoid $\mathcal{D}(\mathcal{G})$ where \mathcal{G} is a crossed module

The definition of an edge symmetric (strict) double groupoid \mathcal{K} (with thin structure) can be found for example in [BH1, BHS, BHKP, BS]. These are 2-truncated cubical sets for which the set of 1-cubes \mathcal{K}_1 is a groupoid, with set of objects given by the set of 0-cubes, and also with two partial compositions, vertical and horizontal, in the set \mathcal{K}_2 of 2-cubes (squares), each defining groupoid structures for which the set of objects is the set of 1-cubes. These horizontal and vertical compositions should verify the interchange law:

$$\begin{pmatrix} k_1 k_2 \\ k_3 k_4 \end{pmatrix} = \begin{pmatrix} k_1 \\ k_3 \end{pmatrix} \begin{pmatrix} k_2 \\ k_4 \end{pmatrix}, \text{ for each } k_1, k_2, k_3, k_4 \in \mathcal{K}_2,$$

familiar in 2-dimensional category theory, and be compatible with faces and degeneracies, in the obvious way. In particular, the identity maps of the vertical and horizontal compositions are given by degenerate squares.

There is also an extra condition that should be verified, which is the existence of a thin structure, meaning that there exist, among the squares of \mathcal{K} , special elements called thin such that:

1. Degenerate squares are thin.
2. Given $a, b, c, d \in \mathcal{K}_1$ with $ab = cd$, there exists a unique thin square k whose boundary is:

$$\begin{array}{ccc} * & \xrightarrow{d} & * \\ c \uparrow & & \uparrow b \\ * & \xrightarrow{a} & * \end{array} ;$$

in other words such that $\partial_d(k) = a, \partial_r(k) = b, \partial_u(k) = d$ and $\partial_l(k) = c$, where we have put $\partial_d = \partial_2^-, \partial_r = \partial_1^+, \partial_u = \partial_2^+$ and $\partial_l = \partial_1^-$.

3. Any composition of thin squares is thin.

Let $\mathcal{G} = (\partial: E \rightarrow G, \triangleright)$ be a crossed module. Given that the categories of crossed modules, categorical groups and double groupoids with a unique object $*$ are equivalent (see [BH1, BH6, BHS, BS, BL]), we can construct a double groupoid $\mathcal{D}(\mathcal{G})$ out of \mathcal{G} . The 1-cubes $\mathcal{D}^1(\mathcal{G})$ of $\mathcal{D}(\mathcal{G})$ are given by all elements of G , with product as composition, and the unique source and target maps to the set $\{*\}$. The 2-cubes $\mathcal{D}^2(\mathcal{G})$ of $\mathcal{D}(\mathcal{G})$, which we will also call squares in \mathcal{G} , have the form:

$$\begin{array}{ccc} * & \xrightarrow{W} & * \\ Z \uparrow & e & \uparrow Y \\ * & \xrightarrow{X} & * \end{array} \quad (2.3)$$

where $X, Y, Z, W \in G$ and $e \in E$ is such that $\partial(e)^{-1}XY = ZW$. The horizontal and vertical compositions are:

$$\begin{array}{ccc} * & \xrightarrow{W} & * \\ Z \uparrow & e & \uparrow Y \\ * & \xrightarrow{X} & * \end{array} \quad \begin{array}{ccc} * & \xrightarrow{W'} & * \\ Y \uparrow & e' & \uparrow Y' \\ * & \xrightarrow{X'} & * \end{array} = \begin{array}{ccc} * & \xrightarrow{WW'} & * \\ Z \uparrow & (X \triangleright e')e & \uparrow Y' \\ * & \xrightarrow{XX'} & * \end{array}$$

and

$$\begin{array}{ccc} * & \xrightarrow{W'} & * \\ Z' \uparrow & e' & \uparrow Y' \\ * & \xrightarrow{W} & * \\ * & \xrightarrow{W} & * \\ Z \uparrow & e & \uparrow Y \\ * & \xrightarrow{X} & * \end{array} = \begin{array}{ccc} * & \xrightarrow{W'} & * \\ ZZ' \uparrow & eZ \triangleright e' & \uparrow Y' \\ * & \xrightarrow{X} & * \end{array}$$

The thin structure on $\mathcal{D}(\mathcal{G})$ is given by: a square is thin if the element of E assigned to it is 1_E .

Alternatively the thin structure can be given by introducing the following special degeneracies, usually called connection maps (not to be confused with differential geometric connections) $\lrcorner, \llcorner, \ulcorner, \lrcorner$: $\mathcal{D}^1(\mathcal{G}) \rightarrow \mathcal{D}^2(\mathcal{G})$, whose images are thin:

$$\begin{array}{ccc} * & \xrightarrow{1_G} & * \\ \lrcorner \uparrow & & \uparrow X^{-1} \\ * & \xrightarrow{X} & * \\ \lrcorner \uparrow & & \uparrow X \\ * & \xrightarrow{1_G} & * \end{array}, \quad \begin{array}{ccc} * & \xrightarrow{X} & * \\ \lrcorner \uparrow & & \uparrow X \\ * & \xrightarrow{1_G} & * \\ \lrcorner \uparrow & & \uparrow X \\ * & \xrightarrow{1_G} & * \end{array}$$

$$\begin{array}{ccc} * & \xrightarrow{1_G} & * \\ X \uparrow & & \uparrow 1_G \\ * & \xrightarrow{X} & * \\ X \uparrow & & \uparrow 1_G \\ * & \xrightarrow{1_G} & * \end{array}, \quad \begin{array}{ccc} * & \xrightarrow{X} & * \\ X^{-1} \uparrow & & \uparrow 1_G \\ * & \xrightarrow{1_G} & * \\ X^{-1} \uparrow & & \uparrow 1_G \\ * & \xrightarrow{1_G} & * \end{array}$$

Here we are using results of [BHS, BH1, BH2, BH3, Hi], where it is shown that the existence of special degeneracies, satisfying a set of axioms, is equivalent to the existence of a thin structure. Then an element of $\mathcal{D}^2(\mathcal{G})$ is thin if and only if it is the composition of degenerate squares and the images of special degeneracies; see [Hi, BHS].

The set $\mathcal{D}^2(\mathcal{G})$ is actually a D_4 -space, where D_4 is the dihedral group of symmetries of the square. This can be inferred from the existence of a thin structure. Consider the following representative elements $\rho_{\pi/2}, r_x, r_y$ and r_{xy} of D_4 , where $\rho_{\pi/2}$ denotes anticlockwise rotation by 90 degrees, and r_x, r_y, r_{xy} denote reflection in the $y = 0, x = 0$ and $x = y$ axis (recall that these last three elements are generators of $D_4 \cong \mathbb{Z}_2^2 \rtimes S_2$). Under the action of these elements of D_4 , the square (2.3) is transformed into, respectively:

$$\begin{array}{cccc} * & \xrightarrow{Y^{-1}} & * & * & \xrightarrow{X} & * & * & \xrightarrow{W^{-1}} & * & * & \xrightarrow{Y} & * \\ W \uparrow & Z^{-1} \triangleright e & \uparrow X & Z^{-1} \uparrow & Z \triangleright e^{-1} & \uparrow Y^{-1} & Y \uparrow & X \triangleright e^{-1} & \uparrow Z & X \uparrow & e^{-1} & \uparrow W \\ * & \xrightarrow{Z^{-1}} & * & * & \xrightarrow{W} & * & * & \xrightarrow{X^{-1}} & * & * & \xrightarrow{Z} & * \end{array}$$

In fact each element of D_4 acts on $\mathcal{D}^2(\mathcal{G})$ by automorphisms, though some times permuting the horizontal and vertical multiplications, or the order of multiplications.

The horizontal and vertical inverses e^{-h} and e^{-v} of an element $e \in \mathcal{D}^2(\mathcal{G})$ are given by $e^{-h} = r_y(e)$ and $e^{-v} = r_x(e)$; we will often identify an element of $\mathcal{D}^2(\mathcal{G})$ with the element of E assigned to it, whenever there is no ambiguity.

There are two particular maps $\Phi, \Phi'_g: \mathcal{D}^2(\mathcal{G}) \rightarrow \mathcal{D}^2(\mathcal{G})$, where $g \in G$, called

folding maps, which we would like to make explicit. These are defined as:

$$\Phi \left(\begin{array}{ccc} * & \xrightarrow{W} & * \\ Z \uparrow & e & \uparrow Y \\ * & \xrightarrow{X} & * \end{array} \right) = \begin{array}{ccc} * & \xrightarrow{ZWY^{-1}X^{-1}} & * \\ 1_G \uparrow & e & \uparrow 1_G \\ * & \xrightarrow{1_G} & * \end{array}$$

and

$$\Phi'_g \left(\begin{array}{ccc} * & \xrightarrow{W} & * \\ Z \uparrow & e & \uparrow Y \\ * & \xrightarrow{X} & * \end{array} \right) = \begin{array}{ccc} * & \xrightarrow{ZWY^{-1}X^{-1}} & * \\ g \uparrow & g \triangleright e & \uparrow g \\ * & \xrightarrow{1_G} & * \end{array}$$

There also exists an action of G on $\mathcal{D}^2(\mathcal{G})$, which has the form:

$$g \triangleright \left(\begin{array}{ccc} * & \xrightarrow{W} & * \\ Z \uparrow & e & \uparrow Y \\ * & \xrightarrow{X} & * \end{array} \right) = \begin{array}{ccc} * & \xrightarrow{gWg^{-1}} & * \\ gZg^{-1} \uparrow & g \triangleright e & \uparrow gYg^{-1} \\ * & \xrightarrow{gXg^{-1}} & * \end{array}$$

2.2.2 Flat \mathcal{G} -colourings, the edge symmetric triple groupoid $\mathcal{T}(\mathcal{G})$ and the nerve $\mathcal{N}(\mathcal{G})$ of the crossed module \mathcal{G}

Going one dimension up, following [BHS, BH1, BH2, BH3, BH6], we can analogously define an edge symmetric triple groupoid $\mathcal{T}(\mathcal{G})$ of thin 3-cubes in \mathcal{G} , from the crossed module $\mathcal{G} = (\partial: E \rightarrow G, \triangleright)$.

The 1- and 2-cubes of $\mathcal{T}(\mathcal{G})$ are already defined, being $\mathcal{T}^1(\mathcal{G}) = \mathcal{D}^1(\mathcal{G})$ and $\mathcal{T}^2(\mathcal{G}) = \mathcal{D}^2(\mathcal{G})$, so let us define the set of thin 3-cubes $\mathcal{T}^3(\mathcal{G})$ of $\mathcal{T}(\mathcal{G})$. Consider the set of assignments (\mathcal{G} -colourings of D^3) of an element of G to each edge of the standard cube $D^3 = [0, 1]^3$ in \mathbb{R}^3 and of an element of E to each face of D^3 . Each of these assignments can be mapped to the set of \mathcal{G} -colourings of D^2 , i.e. assignments of elements of G to the set of edges of the standard square D^2 in \mathbb{R}^2 , and an element of E to its unique face in several different ways, by using the maps $\delta_i^\pm, i = 1, 2, 3$ of 2.1.

Given a \mathcal{G} -colouring \mathbf{c}_2 of D^2 , we put $X_i^\pm(\mathbf{c}_2) = \partial_i^\pm(\mathbf{c}_2) \in G$ as being $\mathbf{c}_2 \circ \delta_i^\pm(D^1)$ where $i = 1, 2$. We also put $e(\mathbf{c}_2) = \mathbf{c}_2(D^2)$. Analogously, if \mathbf{c}_3 is a \mathcal{G} -colouring of D^3 , we put $e_i^\pm(\mathbf{c}_3) = \partial_i^\pm(\mathbf{c}_3)$ as being the colouring of D^2 given by $\mathbf{c}_3 \circ \delta_i^\pm$ where $i = 1, 2, 3$.

Definition 2.7 (Flat \mathcal{G} -colouring) *A \mathcal{G} -colouring \mathbf{c}_2 of D^2 is said to be flat if it yields an element of $\mathcal{D}^2(\mathcal{G})$, in the obvious way, in other words if*

$$\partial(e(\mathbf{c}_2))^{-1} X_2^-(\mathbf{c}_2) X_1^+(\mathbf{c}_2) = X_1^-(\mathbf{c}_2) X_2^+(\mathbf{c}_2).$$

Analogously, a \mathcal{G} -colouring \mathbf{c}_3 of D^3 is said to be flat if:

1. Each restriction $\partial_j^\pm(\mathbf{c}_3)$ of \mathbf{c}_3 is a flat \mathcal{G} -colouring of D^2 .

2. The following holds:

$$\begin{aligned}
& \begin{array}{ccc} \ulcorner(\partial_2^+ \partial_1^-(\mathbf{c}_3)) & e_2^+(\mathbf{c}_3) & \urcorner(\partial_2^+ \partial_1^+(\mathbf{c}_3)) \\ e_3^+(\mathbf{c}_3) = \rho_{\pi/2}(e_1^-(\mathbf{c}_3)) & e_3^-(\mathbf{c}_3) & r_{xy}(e_1^+(\mathbf{c}_3)) \\ \llcorner(\partial_2^- \partial_1^-(\mathbf{c}_3)) & r_y(e_2^-(\mathbf{c}_3)) & \lrcorner(\partial_2^- \partial_1^+(\mathbf{c}_3)) \end{array} \\
& \qquad \qquad \qquad (2.4)
\end{aligned}$$

We will call this the **homotopy addition equation**, following the terminology adopted in [BH5]. Note that we are expressing the fact that the non-abelian composition of five faces of a cube agrees with the sixth face.

The set $\mathcal{T}^3(\mathcal{G})$ of (thin) 3-cubes in \mathcal{G} is given by the set of flat \mathcal{G} -colourings of the 3-cube.

The set $\mathcal{T}^3(\mathcal{G})$ of thin 3-cubes in \mathcal{G} has three interchangeable associative compositions (horizontal, vertical and upwards), as well as boundary maps, $\partial_i^\pm, i = 1, 2, 3$. These compositions are induced by the horizontal and vertical composition of squares in \mathcal{G} in the unique way such that the boundary maps ∂_i^\pm in the transverse directions are groupoid morphisms. By considering the obvious degeneracies $\epsilon^i: \mathcal{D}^1(\mathcal{G}) \rightarrow \mathcal{D}^2(\mathcal{G}), i = 1, 2$ and $\epsilon^i: \mathcal{D}^2(\mathcal{G}) \rightarrow \mathcal{T}^3(\mathcal{G}), i = 1, 2, 3$, obtained by projecting in the i^{th} direction (see 2.1.1), we can see that we obtain a 3-truncated cubical set $\mathcal{T}(\mathcal{G})$, which is a strict triple groupoid.

By continuing this process, one gets a cubical set $\mathcal{N}(\mathcal{G})$, which is called the cubical nerve of \mathcal{G} . The n -cubes of $\mathcal{N}(\mathcal{G})$ are given by all \mathcal{G} -colourings of the n -cube D^n such that for each 2- and 3-dimensional face of D^n the restriction of the colouring to it is flat. This is a cubical manifold if \mathcal{G} is a Lie crossed module. The geometric realisation of $\mathcal{N}(\mathcal{G})$ is called the cubical classifying space of \mathcal{G} ; see [BHS, BH4] and [BH5] for the simplicial version. Note that more generally we can take \mathcal{G} to be a crossed module of groupoids [BHS, FMPo], with completely analogous definitions.

Note that the homotopy addition equation (2.4) can be expressed in several different ways by using the D_4 -symmetry, and applying the maps Φ, Φ'_g . In particular, we get the equivalent equation:

$$\begin{aligned}
\Phi'_{\partial_2^- \partial_1^-(\mathbf{c}_3)}(e_3^+(\mathbf{c}_3)) = & \begin{array}{ccc} e_1^-(\mathbf{c}_3) & e_2^+(\mathbf{c}_3) & r_x(e_1^+(\mathbf{c}_3)) \\ & & r_x(e_2^-(\mathbf{c}_3)) \end{array} \\
& \Phi(e_3^-(\mathbf{c}_3))
\end{aligned} \tag{2.5}$$

2.3 Construction of the thin homotopy double groupoid of a smooth manifold

Let M be a smooth manifold. We now construct the thin homotopy double groupoid $\mathcal{S}_2(M)$ of M . For the analogous construction of the fundamental thin categorical group of a smooth manifold see [FMP1].

2.3.1 1-paths, 2-paths and 1-tracks

Definition 2.8 (1-path) A 1-path is given by a smooth map $\gamma: [0, 1] \rightarrow M$ such that there exists an $\epsilon > 0$ such that γ is constant in $[0, \epsilon] \cup [1 - \epsilon, 1]$; in the terminology of [CP], this can be abbreviated by saying that each end point of γ has a sitting instant. Given a 1-path γ , define the source and target or initial and end point of γ as $\sigma(\gamma) = \gamma(0)$ and $\tau(\gamma) = \gamma(1)$, respectively.

Given two 1-paths γ and ϕ with $\tau(\gamma) = \sigma(\phi)$, their concatenation $\gamma\phi$ is defined in the usual way:

$$(\gamma\phi)(t) = \begin{cases} \gamma(2t), & \text{if } t \in [0, 1/2] \\ \phi(2t - 1), & \text{if } t \in [1/2, 1] \end{cases}$$

Note that the concatenation of two 1-paths is also a 1-path, and in particular is smooth due to the sitting instant condition.

Definition 2.9 (2-paths) A 2-path Γ is given by a smooth map $\Gamma: [0, 1]^2 \rightarrow M$ such that there exists an $\epsilon > 0$ for which:

1. $\Gamma(t, s) = \Gamma(0, s)$ if $0 \leq t \leq \epsilon$ and $s \in [0, 1]$,
2. $\Gamma(t, s) = \Gamma(1, s)$ if $1 - \epsilon \leq t \leq 1$ and $s \in [0, 1]$,
3. $\Gamma(t, s) = \Gamma(t, 0)$ if $0 \leq s \leq \epsilon$ and $t \in [0, 1]$,
4. $\Gamma(t, s) = \Gamma(t, 1)$ if $1 - \epsilon \leq s \leq 1$ and $t \in [0, 1]$.

We abbreviate this by saying that Γ has a product structure close to the boundary of $[0, 1]^2$.

Given a 2-path Γ , define the following 1-paths:

$$\begin{aligned} \partial_l(\Gamma)(s) &= \Gamma(0, s), s \in [0, 1], & \partial_r(\Gamma)(s) &= \Gamma(1, s), s \in [0, 1], \\ \partial_d(\Gamma)(t) &= \Gamma(t, 0), t \in [0, 1], & \partial_u(\Gamma)(t) &= \Gamma(t, 1), t \in [0, 1]. \end{aligned}$$

If Γ and Γ' are 2-paths such that $\partial_r(\Gamma) = \partial_l(\Gamma')$ their horizontal concatenation $\Gamma \circ_h \Gamma'$ is defined in the obvious way, in other words:

$$(\Gamma \circ_h \Gamma')(t, s) = \begin{cases} \Gamma(2t, s), & \text{if } t \in [0, 1/2] \text{ and } s \in [0, 1] \\ \Gamma'(2t - 1, s), & \text{if } t \in [1/2, 1] \text{ and } s \in [0, 1] \end{cases}$$

Similarly, if $\partial_u(\Gamma) = \partial_d(\Gamma')$ we can define a vertical concatenation $\Gamma \circ_v \Gamma'$ as:

$$(\Gamma \circ_v \Gamma')(t, s) = \begin{cases} \Gamma(t, 2s), & \text{if } s \in [0, 1/2] \text{ and } t \in [0, 1] \\ \Gamma'(t, 2s - 1), & \text{if } s \in [1/2, 1] \text{ and } t \in [0, 1] \end{cases}$$

Note that again both concatenations are smooth due to the product structure condition.

Definition 2.10 *Two 1-paths ϕ and γ are said to be rank-1 homotopic (and we write $\phi \cong_1 \gamma$) if there exists a 2-path Γ such that:*

1. $\partial_l(\Gamma)$ and $\partial_r(\Gamma)$ are constant.
2. $\partial_u(\Gamma) = \gamma$ and $\partial_d(\Gamma) = \phi$.
3. $\text{Rank}(\mathcal{D}_v\Gamma) \leq 1$, for each $v \in [0, 1]^2$.

Here \mathcal{D} denotes the derivative.

Thus if γ and ϕ are rank-1 homotopic, they have the same initial and end-points. Note also that rank-1 homotopy is an equivalence relation. Given a 1-path γ , the equivalence class to which it belongs is denoted by $[\gamma]$. Rank-1 homotopy is one of a number of notions of “thin” equivalence between paths or loops, and was introduced in [CP], following a suggestion by A. Machado.

We denote the set of 1-paths of M by $S_1(M)$. The quotient of $S_1(M)$ by the relation of thin homotopy is denoted by $\mathcal{S}_1(M)$. We call the elements of $\mathcal{S}_1(M)$ 1-tracks. The concatenation of 1-tracks together with the source and target maps $\sigma, \tau: \mathcal{S}_1(M) \rightarrow M$, defines a groupoid $\mathcal{S}_1(M)$ whose set of morphisms is $\mathcal{S}_1(M)$ and whose set of objects is M .

2.3.2 2-Tracks

We recall the notation of 2.1.1.

Definition 2.11 *Two 2-paths Γ and Γ' are said to be rank-2 homotopic (and we write $\Gamma \cong_2 \Gamma'$) if there exists a smooth map $J: [0, 1]^3 \rightarrow M$ such that:*

1. $J(t, s, 0) = \Gamma(t, s)$, $J(t, s, 1) = \Gamma'(t, s)$ for $s, t \in [0, 1]$. In other words $J \circ \delta_3^- = \Gamma$ and $J \circ \delta_3^+ = \Gamma'$.
2. $J \circ \delta_i^\pm$ is a rank-1 homotopy from $\Gamma \circ \delta_i^\pm$ to $\Gamma' \circ \delta_i^\pm$, where $i = 1, 2$.
3. There exists an $\epsilon > 0$ such that $J(t, s, x) = J(t, s, 0)$ if $x \leq \epsilon$ and $s, t \in [0, 1]$, and analogously for all the other faces of $[0, 1]^3$. We will describe this condition by saying that J has a product structure close to the boundary of $[0, 1]^3$.
4. $\text{Rank}(\mathcal{D}_v J) \leq 2$ for any $v \in [0, 1]^3$.

Note that rank-2 homotopy is an equivalence relation. To prove transitivity we need to use the penultimate condition of the previous definition. We denote by $S_2(M)$ the set of all 2-paths of M . The quotient of $S_2(M)$ by the relation of rank-2 homotopy is denoted by $\mathcal{S}_2(M)$. We call the elements of $\mathcal{S}_2(M)$ 2-tracks. If $\Gamma \in S_2(M)$, we denote the equivalence class in $\mathcal{S}_2(M)$ to which Γ belongs by $[\Gamma]$.

2.3.3 Horizontal and vertical compositions of 2-tracks

Suppose that Γ and Γ' are 2-paths with $\partial_u(\Gamma) \cong_1 \partial_d(\Gamma')$. Choose a rank-1 homotopy J connecting $\partial_u(\Gamma)$ and $\partial_d(\Gamma')$. Then $[\Gamma] \circ_v [\Gamma']$ is defined as $[(\Gamma \circ_v J) \circ_v \Gamma']$. The fact that this composition is well defined in $\mathcal{S}_2(M)$ is not tautological (and was left as an open problem in [MP]). However this follows immediately from the following lemma proved in [FMP1].

Lemma 2.12 *Let $f: \partial(D^3) \rightarrow M$ be a smooth map such that $\text{Rank}(\mathcal{D}_v f) \leq 1$, for each $v \in \partial(D^3)$. Here $D^3 = [0, 1]^3$. Suppose that f is constant in a neighbourhood of each vertex of $\partial(D^3)$. In addition, suppose also that in a neighbourhood $I \times [-\epsilon, \epsilon]$ of each edge I of $\partial(D^3)$, $f(x, t) = \phi(x)$, where $(x, t) \in I \times [-\epsilon, \epsilon]$ and $\phi: I \rightarrow M$ is smooth. Then f can be extended to a smooth map $F: D^3 \rightarrow M$ such that $\text{Rank}(\mathcal{D}_w F) \leq 2$, for each $w \in D^3$. Moreover we can choose F so that it has a product structure close to the boundary of D^3 .*

Remark 2.13 *This basically says that any smooth map $f: S^2 \rightarrow M$ for which the rank of the derivative is less than or equal to 1, for each point in S^2 , can be extended to all of the unit 3-ball, in such a way that the rank of the derivative of the resulting map at each point is less than or equal to 2.*

Analogously the horizontal composition of 2-paths descends to $\mathcal{S}_2(M)$. These compositions are obviously associative, and admit units and inverses. Note that the interchange law is also verified.

Finally, a 2-track $[\Gamma]$ is thin if it admits a representative which is a thin map, in other words for which $\text{Rank}(\mathcal{D}_x \Gamma) \leq 1$, for each $x \in [0, 1]^2$. Lemma 2.12 implies that if $a, b, c, d: [0, 1] \rightarrow M$ are 1-paths with $[ab] = [cd]$ then there exists a unique 2-track $[\Gamma]$ for which $\partial_d([\Gamma]) = [a]$, $\partial_r([\Gamma]) = [b]$, $\partial_l([\Gamma]) = [c]$ and $\partial_u([\Gamma]) = [d]$.

Therefore the following theorem holds:

Theorem 2.14 *Let M be a smooth manifold. The horizontal and vertical compositions in $\mathcal{S}_2(M)$ together with the boundary maps $\partial_u, \partial_d, \partial_l, \partial_r: \mathcal{S}_2(M) \rightarrow \mathcal{S}_1(M)$ define a double groupoid $\mathcal{S}_2(M)$, called the thin homotopy double groupoid of M , whose set of objects is given by all points of M , set of 1-morphisms by the set $\mathcal{S}_1(M)$ of 1-tracks on M , and set of 2-morphisms by all 2-tracks in $\mathcal{S}_2(M)$. In addition, $\mathcal{S}_2(M)$ admits a thin structure given by: a 2-track is thin if it admits a representative whose derivative has rank less than or equal to 1 (in other words if it is thin as a smooth map).*

Remark 2.15 *Another possible argument to prove that the compositions of 2-tracks are well defined is to adapt the arguments in [BH1, BHS, BH2, BH3, BHKP], which lead to the construction of the fundamental double groupoid of a triple of spaces and of a Hausdorff space (and can be continued to define the homotopy ω -groupoid of a filtered space). The same technique therefore leads to the construction of the fundamental ω -groupoid of a smooth manifold. Details will appear elsewhere.*

This construction should be compared with [HKK, BHKP], where the thin strict 2-groupoid of a Hausdorff space was defined, using a different notion of thin equivalence (factoring through a graph). For analogous non-strict constructions see [M, BS1, MP].

2.4 Connections and categorical connections in principal fibre bundles

To approach non-abelian integral calculus based on a crossed module, it is convenient (since the proofs are slightly easier) to consider categorical connections in principal fibre bundles. For details of this approach see [FMP1]. For a treatment of non-abelian integral calculus based on a crossed module, using forms on the base space of the principal bundle, see [SW1, SW2, SW3, FMP2].

2.4.1 Differential crossed module valued forms

Let M be a smooth manifold with its Lie algebra of vector fields denoted by $\mathcal{X}(M)$. Consider also a differential crossed module $\mathfrak{G} = (\partial: \mathfrak{e} \rightarrow \mathfrak{g}, \triangleright)$. In particular the map $(X, e) \in \mathfrak{g} \times \mathfrak{e} \mapsto X \triangleright e \in \mathfrak{e}$ is bilinear.

Let $a \in \mathcal{A}^n(M, \mathfrak{g})$ and $b \in \mathcal{A}^m(M, \mathfrak{e})$ be \mathfrak{g} - and \mathfrak{e} -valued (respectively) differential forms on M . We define $a \otimes^\triangleright b$ as being the \mathfrak{e} -valued covariant tensor field on M such that

$$(a \otimes^\triangleright b)(A_1, \dots, A_n, B_1, \dots, B_m) = a(A_1, \dots, A_n) \triangleright b(B_1, \dots, B_m); A_i, B_j \in \mathcal{X}(M).$$

We also define an alternating tensor field $a \wedge^\triangleright b \in \mathcal{A}^{n+m}(M, \mathfrak{e})$, being given by

$$a \wedge^\triangleright b = \frac{(n+m)!}{n!m!} \text{Alt}(a \otimes^\triangleright b).$$

Here Alt denotes the natural projection from the vector space of \mathfrak{e} -valued covariant tensor fields on M onto the vector space of \mathfrak{e} -valued differential forms on M . For example, if $a \in \mathcal{A}^1(M, \mathfrak{g})$ and $b \in \mathcal{A}^2(M, \mathfrak{e})$, then $a \wedge^\triangleright b$ satisfies:

$$(a \wedge^\triangleright b)(X, Y, Z) = a(X) \triangleright b(Y, Z) + a(Y) \triangleright b(Z, X) + a(Z) \triangleright b(X, Y), \quad (2.6)$$

where $X, Y, Z \in \mathcal{X}(M)$.

2.4.2 Categorical connections in principal fibre bundles

In [FMP1] we defined categorical connections in terms of differential forms on the total space of a principal fibre bundle. Let M be a smooth manifold and G a Lie group with Lie algebra \mathfrak{g} . Let also $\pi: P \rightarrow M$ be a smooth principal G -bundle over M . Denote the fibre at each point $x \in M$ as $P_x \doteq \pi^{-1}(x)$.

Definition 2.16 *Let $\mathcal{G} = (\partial: E \rightarrow G, \triangleright)$ be a Lie crossed module, where \triangleright is a Lie group left action of G on E by automorphisms. Let also $\mathfrak{G} = (\partial: \mathfrak{e} \rightarrow \mathfrak{g}, \triangleright)$ be the associated differential crossed module. A \mathcal{G} -categorical connection on P is a pair (ω, m) , where ω is a connection 1-form on P , i.e. $\omega \in \mathcal{A}^1(P, \mathfrak{g})$ is a 1-form on P with values in \mathfrak{g} such that:*

- $R_g^*(\omega) = g^{-1}\omega g$, for each $g \in G$, (i.e. ω is G -equivariant)
- $\omega(A^\#) = A$, for each $A \in \mathfrak{g}$;

where $A^\#$ denotes the vertical vector field associated to A coming from the G -action on P , and $m \in \mathcal{A}^2(P, \mathfrak{e})$ is a 2-form on P with values in \mathfrak{e} , the Lie algebra of E , such that:

- m is G -equivariant, in the sense that $R_g^*(m) = g^{-1} \triangleright m$ for each $g \in G$.
- m is horizontal, in other words:

$$m(X, Y) = m(X^H, Y^H), \text{ for each } X, Y \in \mathcal{X}(P).$$

In particular $m(X_u, Y_u) = 0$ if either of the vectors $X_u, Y_u \in T_u P$ is vertical, where $u \in P$. Here the map $X \in \mathcal{X}(P) \mapsto X^H \in \mathcal{X}(P)$ denotes the horizontal projection of vector fields on P with respect to the connection 1-form ω .

Finally (ω, m) satisfies the “vanishing of the fake curvature condition” [BS1, BS2, BrMe]:

$$\partial(m) = \Omega, \tag{2.7}$$

where $\Omega = d\omega + \frac{1}{2}\omega \wedge^{\text{ad}} \omega \in \mathcal{A}^2(P, \mathfrak{g})$ is the curvature 2-form of ω .

2.4.3 The categorical curvature 3-form of a \mathcal{G} -categorical connection

Let P be a principal G -bundle over M . Let $\omega \in \mathcal{A}^1(P, \mathfrak{g})$ be a connection 1-form on P . Given an n -form a on P , the exterior covariant derivative of a is given by

$$Da = da \circ (H \times H \dots \times H).$$

Let $\Omega \in \mathcal{A}^2(P, \mathfrak{g})$ be the (G -equivariant) curvature 2-form of the connection ω . It can be defined as the exterior covariant derivative $D\omega$ of the connection 1-form ω and also by the Cartan structure equation $\Omega = d\omega + \frac{1}{2}\omega \wedge^{\text{ad}} \omega$. It is therefore natural to define:

Definition 2.17 (Categorical curvature) *Let $\mathcal{G} = (\partial: E \rightarrow G, \triangleright)$ be a crossed module of Lie groups, and let $P \rightarrow M$ be a smooth principal G -bundle. The categorical curvature 3-form or 2-curvature 3-form of a \mathcal{G} -categorical connection (ω, m) on P is defined as $\mathcal{M} = Dm$, where the exterior covariant derivative D is taken with respect to ω .*

The following equation is an analogue of Cartan’s structure equation.

Proposition 2.18 (Categorical structure equation) *We have: $\mathcal{M} = dm + \omega \wedge^\triangleright m$. In particular the 2-curvature 3-form \mathcal{M} is G -equivariant, in other words: $R_g^*(\mathcal{M}) = g^{-1} \triangleright \mathcal{M}$, for each $g \in G$.*

This categorical structure equation follows directly from the following natural lemma, easy to prove; see [FMP1]:

Lemma 2.19 *Let a be a G -equivariant horizontal n -form in P . Then $Da = da + \omega \wedge^\triangleright a$.*

Recall that the usual Bianchi identity can be written as $D\Omega = 0$, which is the same as saying that $d\Omega + \omega \wedge^{\text{ad}} \Omega = 0$.

Corollary 2.20 *The 2-curvature 3-form of a categorical connection is \mathfrak{k} -valued, where \mathfrak{k} is the Lie algebra of $K = \ker(\partial)$.*

Proof. We have $\partial(\mathcal{M}) = \partial(dm + \omega \wedge^\triangleright m) = d\Omega + \omega \wedge^{\text{ad}} \Omega = 0$, by the Bianchi identity. ■

The 2-curvature 3-form of a categorical connection satisfies the following.

Proposition 2.21 (2-Bianchi identity) *Let $\mathcal{M} \in \mathcal{A}^3(P, \mathfrak{e})$ be the 2-curvature 3-form of (ω, m) . Then the exterior covariant derivative $D\mathcal{M}$ of \mathcal{M} vanishes, which by Lemma 2.19 is the same as: $d\mathcal{M} + \omega \wedge^\triangleright \mathcal{M} = 0$.*

2.4.4 Local form

Let $P \rightarrow M$ be a principal G -bundle with a categorical connection (ω, m) . Let $\{U_i\}$ be an open cover of M , with local sections $\sigma_i: U_i \rightarrow P$ of P . The local form of (ω, m) is given by the forms (ω_i, m_i) , where $\omega_i = \sigma_i^*(\omega)$ and $m_i = \sigma_i^*(m)$, and we have $\partial(m_i) = d\omega_i + \frac{1}{2}\omega_i \wedge^{\text{ad}} \omega_i = \Omega_i = \sigma_i^*(\Omega)$, and also $\omega_j = g_{ij}^{-1}\omega_i g_{ij} + g_{ij}^{-1}dg_{ij}$ and $m_j = g_{ij}^{-1} \triangleright m_i$. Here $\sigma_i g_{ij} = \sigma_j$. Conversely, given forms $\{(\omega_i, m_i)\}$ satisfying these conditions then there exists a unique categorical connection (ω, m) in P whose local form (with respect to the given sections σ_i) is (ω_i, m_i) .

Note that locally the 2-curvature 3-form of a categorical connection reads $\mathcal{M}_i = dm_i + \omega_i \wedge^\triangleright m_i$, with $\mathcal{M}_j = g_{ij}^{-1} \triangleright \mathcal{M}_i$ and the 2-Bianchi identity is $d\mathcal{M}_i + \omega_i \wedge^\triangleright \mathcal{M}_i = 0$.

2.5 Holonomy and categorical holonomy in a principal fibre bundle

Let P be a principal G -bundle over the manifold M . Let $\omega \in \mathcal{A}^1(P, \mathfrak{g})$ be a connection on P . Recall that ω determines a parallel transport along smooth curves. Specifically, given $x \in M$ and a smooth curve $\gamma: [0, 1] \rightarrow M$, with $\gamma(0) = x$, then there exists a smooth map:

$$(t, u) \in [0, 1] \times P_x \mapsto \mathcal{H}_\omega(\gamma, t, u) \in P,$$

uniquely defined by the conditions:

1. $\frac{d}{dt} \mathcal{H}_\omega(\gamma, t, u) = \left(\widetilde{\frac{d}{dt} \gamma(t)} \right)_{\mathcal{H}_\omega(\gamma, t, u)}$; for each $t \in [0, 1]$, for each $u \in P_x$, where $\widetilde{}$ denotes the horizontal lift,
2. $\mathcal{H}_\omega(\gamma, 0, u) = u$; for each $u \in P_x$.

In particular this implies that $\mathcal{H}_\omega(\gamma, t)$, given by $u \mapsto \mathcal{H}_\omega(\gamma, t, u)$, maps P_x bijectively into $P_{\gamma(t)}$, for any $t \in [0, 1]$. We will also use the notation $\mathcal{H}_\omega(\gamma, 1, u) \doteq u\gamma$. Therefore if γ and γ' are such that $\gamma(1) = \gamma'(0)$ we have: $(u\gamma)\gamma' = u(\gamma\gamma')$. Recall that the parallel transport is G -equivariant, in other words:

$$\mathcal{H}_\omega(\gamma, t, ug) = \mathcal{H}_\omega(\gamma, t, u)g, \text{ for each } g \in G, \text{ for each } u \in P_x.$$

2.5.1 A form of the Ambrose-Singer Theorem

Let M be a smooth manifold. Let $D^n \doteq [0, 1]^n$ be the n -cube, where $n \in \mathbb{N}$. A map $f: D^n \rightarrow M$ is said to be smooth if its partial derivatives of any order exist and are continuous as maps $D^n \rightarrow M$.

The well known relation between curvature and parallel transport can be summarised in the following lemma, proved for instance in [FMP1, SW2].

Lemma 2.22 *Let G be a Lie group with Lie algebra \mathfrak{g} . Let P be a smooth principal G -bundle over the manifold M . Consider a smooth map $\Gamma: [0, 1]^2 \rightarrow M$. For each $s, t \in [0, 1]$, define the curves $\gamma_s, \gamma^t: [0, 1] \rightarrow M$ as $\gamma_s(t) = \gamma^t(s) = \Gamma(t, s)$. Consider a connection $\omega \in \mathcal{A}^1(P, \mathfrak{g})$. Choose $u \in P_{\gamma^0(0)}$, and let $u_s = \mathcal{H}_\omega(\gamma^0, s, u)$, and analogously $u^t = \mathcal{H}_\omega(\gamma_0, t, u)$ where $s, t \in [0, 1]$. The following holds for each $s, t \in [0, 1]$:*

$$\omega \left(\frac{\partial}{\partial s} \mathcal{H}_\omega(\gamma_s, t, u_s) \right) = \int_0^t \Omega \left(\widetilde{\frac{\partial}{\partial t'} \gamma_s(t')}, \widetilde{\frac{\partial}{\partial s} \gamma_s(t')} \right)_{\mathcal{H}_\omega(\gamma_s, t', u_s)} dt', \quad (2.8)$$

and by reversing the roles of s and t we also have:

$$\omega \left(\frac{\partial}{\partial t} \mathcal{H}_\omega(\gamma^t, s, u^t) \right) = - \int_0^s \Omega \left(\widetilde{\frac{\partial}{\partial t} \gamma_{s'}(t)}, \widetilde{\frac{\partial}{\partial s'} \gamma_{s'}(t)} \right)_{\mathcal{H}_\omega(\gamma^t, s', u^t)} ds'. \quad (2.9)$$

Continuing the notation of the previous lemma, define the elements $\overset{\omega}{g}_\Gamma(u, t, s)$ by the rule:

$$\mathcal{H}_\omega(\gamma^t, s, u^t) \overset{\omega}{g}_\Gamma(u, t, s) = \mathcal{H}_\omega(\gamma_s, t, u_s).$$

Therefore

$$u \overset{\omega}{g}_\Gamma(u, t, s) = \mathcal{H}_\omega(\hat{\gamma}, 1, u)$$

where $\hat{\gamma}$ is the curve $\hat{\gamma} = \partial\Gamma'$, starting in $\Gamma(0, 0)$ and oriented clockwise, and Γ' is the truncation of Γ such that $\Gamma'(t', s') = \Gamma(t't, s's)$, for $0 \leq s', t' \leq 1$.

By using the fact that $\frac{\partial}{\partial t} \mathcal{H}_\omega(\gamma_s, t, u_s)$ is horizontal it follows that:

$$\omega \left(\frac{\partial}{\partial t} \left(\mathcal{H}_\omega(\gamma^t, s, u^t) \overset{\omega}{g}_\Gamma(u, t, s) \right) \right) = 0.$$

Thus, by using the Leibniz rule together with the fact that ω is a connection 1-form,

$$(\overset{\omega}{g}_\Gamma(u, t, s))^{-1} \omega \left(\frac{\partial}{\partial t} \mathcal{H}_\omega(\gamma^t, s, u^t) \right) \overset{\omega}{g}_\Gamma(u, t, s) + (\overset{\omega}{g}_\Gamma(u, t, s))^{-1} \frac{\partial}{\partial t} \overset{\omega}{g}_\Gamma(u, t, s) = 0.$$

Therefore:

$$\frac{\partial}{\partial t} g_{\Gamma}^{\omega}(u, t, s) = \left(\int_0^s \Omega \left(\widetilde{\frac{\partial}{\partial t} \gamma_{s'}(t)}, \widetilde{\frac{\partial}{\partial s'} \gamma_{s'}(t)} \right)_{\mathcal{H}_{\omega}(\gamma^t, s', u^t)} ds' \right) g_{\Gamma}^{\omega}(u, t, s). \quad (2.10)$$

Analogously we have (since $\frac{\partial}{\partial s} \mathcal{H}_{\omega}(\gamma^t, s, u^t)$ is horizontal):

$$\frac{\partial}{\partial s} g_{\Gamma}^{\omega}(u, t, s) = g_{\Gamma}^{\omega}(u, t, s) \int_0^t \Omega \left(\widetilde{\frac{\partial}{\partial t'} \gamma_s(t')}, \widetilde{\frac{\partial}{\partial s} \gamma_s(t')} \right)_{\mathcal{H}_{\omega}(\gamma_s, t', u_s)} dt'. \quad (2.11)$$

2.5.2 Categorical holonomy in a principal fibre bundle

Let P be a principal fibre bundle with a \mathcal{G} -categorical connection (ω, m) . Here $\mathcal{G} = (E \xrightarrow{\partial} G, \triangleright)$ is a Lie crossed module, where \triangleright is a Lie group left action of G on E by automorphisms. Let also $\mathfrak{G} = (\partial: \mathfrak{e} \rightarrow \mathfrak{g}, \triangleright)$ be the associated differential crossed module.

As before, for each smooth map $\Gamma: [0, 1]^2 \rightarrow M$, let $\gamma_s(t) = \gamma^t(s) = \Gamma(t, s)$. Let $a = \Gamma(0, 0)$. Let also $u \in P_a$, $u_s = \mathcal{H}(\gamma^0, s, u)$ and $u^t = \mathcal{H}(\gamma_0, t, u)$. Define the function ${}^{(\omega, m)}e_{\Gamma}: P_a \times [0, 1]^2 \rightarrow E$ as being the solution of the differential equation:

$$\frac{\partial}{\partial s} {}^{(\omega, m)}e_{\Gamma}(u, t, s) = {}^{(\omega, m)}e_{\Gamma}(u, t, s) \int_0^t m \left(\widetilde{\frac{\partial}{\partial t'} \gamma_s(t')}, \widetilde{\frac{\partial}{\partial s} \gamma_s(t')} \right)_{\mathcal{H}_{\omega}(\gamma_s, t', u_s)} dt', \quad (2.12)$$

with initial condition ${}^{(\omega, m)}e_{\Gamma}(u, t, 0) = 1_E$, for each $t \in [0, 1]$. Let ${}^{(\omega, m)}e_{\Gamma}(u) \doteq {}^{(\omega, m)}e_{\Gamma}(u, 1, 1)$. Compare with equations (2.10) and (2.11). The apparently non-symmetric way the horizontal and vertical directions are treated will be dealt with later.

Given a smooth map $\Gamma: [0, 1]^2 \rightarrow M$, define:

$$\mathcal{X}_{\Gamma} = \gamma_0, \quad \mathcal{Y}_{\Gamma} = \gamma^1, \quad \mathcal{Z}_{\Gamma} = \gamma^0 \quad \text{and} \quad \mathcal{W}_{\Gamma} = \gamma_1.$$

Theorem 2.23 (Non-Abelian Green's Theorem, bundle form) *For any $u \in P_a$ we have:*

$$\mathcal{H}_{\omega}(\mathcal{X}_{\Gamma} \mathcal{Y}_{\Gamma}, 1, u) \partial \left({}^{(\omega, m)}e_{\Gamma}(u) \right) = \mathcal{H}_{\omega}(\mathcal{Z}_{\Gamma} \mathcal{W}_{\Gamma}, 1, u),$$

or, in the other notation of section 2.5,

$$u \mathcal{X}_{\Gamma} \mathcal{Y}_{\Gamma} \partial \left({}^{(\omega, m)}e_{\Gamma}(u) \right) = u \mathcal{Z}_{\Gamma} \mathcal{W}_{\Gamma}.$$

Proof. Let $k_x = \mathcal{H}_\omega(\gamma^1, x, u^1)$ and $l_x = \mathcal{H}_\omega(\gamma_x, 1, u_x)$. Let $x \mapsto g_x \in G$ be defined as $k_x g_x = l_x$. We have, since $(\frac{d}{dx} k_x) g_x$ is horizontal:

$$\omega \left(\frac{d}{dx} (k_x g_x) \right) = \omega \left(k_x \frac{d}{dx} g_x \right) = \omega \left(k_x g_x g_x^{-1} \frac{d}{dx} g_x \right) = g_x^{-1} \frac{d}{dx} g_x.$$

On the other hand:

$$\omega \left(\frac{d}{dx} (k_x g_x) \right) = \omega \left(\frac{d}{dx} l_x \right) = \int_0^1 \Omega \left(\widetilde{\frac{\partial}{\partial t} \gamma_x(t)}, \widetilde{\frac{\partial}{\partial x} \gamma_x(t)} \right)_{\mathcal{H}_\omega(\gamma_x, t, u_x)} dt.$$

Therefore

$$\frac{d}{dx} g_x = g_x \int_0^1 \Omega \left(\widetilde{\frac{\partial}{\partial t} \gamma_x(t)}, \widetilde{\frac{\partial}{\partial x} \gamma_x(t)} \right)_{\mathcal{H}_\omega(\gamma_x, t, u_x)} dt. \quad (2.13)$$

This is a differential equation satisfied also by $x \mapsto \partial^{(\omega, m)}(e_\Gamma(u, x, 1))$, by the vanishing of the fake curvature condition $\partial(m) = \Omega$, and both have the same initial conditions. ■

Note that it follows from the Non-Abelian Green's Theorem that:

$$\mathcal{H}_\omega(\gamma^t, s, u^t) \partial^{(\omega, m)}(e_\Gamma(u, t, s)) = \mathcal{H}_\omega(\gamma_s, t, u_s), \text{ for each } t, s \in [0, 1]. \quad (2.14)$$

Lemma 2.24 (Vertical multiplication) *We have:*

$$e_{\Gamma \circ_\vee \Gamma'}^{(\omega, m)}(u) = e_\Gamma^{(\omega, m)}(u) e_{\Gamma'}^{(\omega, m)}(u \mathcal{Z}_\Gamma).$$

Here $\Gamma, \Gamma': [0, 1]^2 \rightarrow M$ are smooth maps such that $\partial_u(\Gamma) = \partial_d(\Gamma')$ and moreover $\Gamma \circ_\vee \Gamma'$ is smooth.

Proof. Obvious from the definition. ■

Lemma 2.25 (Vertical inversion) *We have:*

$$e_\Gamma^{(\omega, m)}(u) e_{\Gamma^{-\vee}}^{(\omega, m)}(u \mathcal{Z}_\Gamma) = 1_E.$$

Here $\Gamma^{-\vee}$ denotes the obvious vertical reversion of $\Gamma: [0, 1]^2 \rightarrow M$.

Proof. Obvious from the definition. ■

Lemma 2.26 (Horizontal multiplication) *We have:*

$$e_{\Phi \circ_{\text{h}} \Psi}^{(\omega, m)}(u) = e_\Psi^{(\omega, m)}(u \mathcal{X}_\Phi) e_\Phi^{(\omega, m)}(u).$$

Here $\Phi, \Psi': [0, 1]^2 \rightarrow M$ are smooth maps such that $\partial_r(\Phi) = \partial_l(\Psi)$ and moreover $\Phi \circ_{\text{h}} \Psi$ is smooth.

Proof. Let $\Gamma = \Phi \circ_h \Psi$. As before put $\phi_s(t) = \phi^t(s) = \Phi(t, s)$ and $\psi_s(t) = \psi^t(s) = \Psi(t, s)$. We have:

$$\begin{aligned} & \frac{\partial}{\partial s} \left(e_{\Psi}^{(\omega, m)}(u\mathcal{X}_{\Phi}, 1, s) e_{\Phi}^{(\omega, m)}(u, 1, s) \right) \\ &= e_{\Psi}^{(\omega, m)}(u\mathcal{X}_{\Phi}, 1, s) e_{\Phi}^{(\omega, m)}(u, 1, s) \left(\int_0^1 m \left(\frac{\partial}{\partial t} \widetilde{\phi_s(t)}, \frac{\partial}{\partial s} \widetilde{\phi_s(t)} \right)_{\mathcal{H}_{\omega}(\phi_s, t, u_s)} dt \right) \\ &+ e_{\Psi}^{(\omega, m)}(u\mathcal{X}_{\Phi}, 1, s) \left(\int_0^1 m \left(\frac{\partial}{\partial t} \widetilde{\psi_s(t)}, \frac{\partial}{\partial s} \widetilde{\psi_s(t)} \right)_{\mathcal{H}_{\omega}(\psi_s, t, (u\mathcal{X}_{\Phi})_s)} dt \right) e_{\Phi}^{(\omega, m)}(u, 1, s) \\ &= Q + W. \end{aligned}$$

Here $(u\mathcal{X}_{\Phi})_s = \mathcal{H}_{\omega}(\mathcal{Z}_{\Psi}, s, u\mathcal{X}_{\Phi})$. Let us analyse each term separately. We have:

$$Q = e_{\Psi}^{(\omega, m)}(u\mathcal{X}_{\Phi}, 1, s) e_{\Phi}^{(\omega, m)}(u, 1, s) \left(\int_0^{\frac{1}{2}} m \left(\frac{\partial}{\partial t} \widetilde{\gamma_s(t)}, \frac{\partial}{\partial s} \widetilde{\gamma_s(t)} \right)_{\mathcal{H}_{\omega}(\gamma_s, t, u_s)} dt \right)$$

where $\gamma_s(t) = \Phi \circ_h \Psi(t, s)$. On the other hand:

$$\begin{aligned} W &= e_{\Psi}^{(\omega, m)}(u\mathcal{X}_{\Phi}, 1, s) e_{\Phi}^{(\omega, m)}(u, 1, s) \\ &\left(\partial(e_{\Phi}^{(\omega, m)}(u, 1, s))^{-1} \triangleright \left(\int_0^1 m \left(\frac{\partial}{\partial t} \widetilde{\psi_s(t)}, \frac{\partial}{\partial s} \widetilde{\psi_s(t)} \right)_{\mathcal{H}_{\omega}(\psi_s, t, (u\mathcal{X}_{\Phi})_s)} dt \right) \right), \end{aligned} \tag{2.15}$$

and therefore

$$\begin{aligned} W &= e_{\Psi}^{(\omega, m)}(u\mathcal{X}_{\Phi}, 1, s) e_{\Phi}^{(\omega, m)}(u, 1, s) \\ &\left(\int_0^1 m \left(\frac{\partial}{\partial t} \widetilde{\psi_s(t)}, \frac{\partial}{\partial s} \widetilde{\psi_s(t)} \right)_{\mathcal{H}_{\omega}(\psi_s, t, (u\mathcal{X}_{\Phi})_s \partial(e_{\Phi}^{(\omega, m)}(u, 1, s)))} dt \right) \\ &= e_{\Psi}^{(\omega, m)}(u\mathcal{X}_{\Phi}, 1, s) e_{\Phi}^{(\omega, m)}(u, 1, s) \left(\int_0^1 m \left(\frac{\partial}{\partial t} \widetilde{\psi_s(t)}, \frac{\partial}{\partial s} \widetilde{\psi_s(t)} \right)_{\mathcal{H}_{\omega}(\psi_s, t, u_s \phi_s)} dt \right) \\ &= e_{\Psi}^{(\omega, m)}(u\mathcal{X}_{\Phi}, 1, s) e_{\Phi}^{(\omega, m)}(u, 1, s) \left(\int_{\frac{1}{2}}^1 m \left(\frac{\partial}{\partial t} \widetilde{\gamma_s(t)}, \frac{\partial}{\partial s} \widetilde{\gamma_s(t)} \right)_{\mathcal{H}_{\omega}(\gamma_s, t, u_s)} dt \right). \end{aligned}$$

Therefore both sides of the equation of the lemma satisfy the same differential equation, and they have the same initial condition. ■

Lemma 2.27 (Horizontal inversion) *We have:*

$$e_{\Gamma^{-h}}^{(\omega, m)}(u, \mathcal{X}_\Gamma) e_\Gamma^{(\omega, m)}(u) = 1_E,$$

where Γ^{-h} denotes the obvious horizontal reversion of $\Gamma: [0, 1]^2 \rightarrow M$.

Proof. Analogous to the proof of the previous result. ■

Lemma 2.28 (Gauge transformations) *We have:*

$$e_\Gamma^{(\omega, m)}(ug) = g^{-1} \triangleright e_\Gamma^{(\omega, m)}(u).$$

Proof. Analogous to the proof of the previous result. ■

2.5.3 The Non-Abelian Fubini's Theorem

We continue with the notation of 2.5.2. Again let $\Gamma: [0, 1]^2 \rightarrow M$ be a smooth map, $a = \Gamma(0, 0)$ and $u \in P_a$. Define $f_\Gamma^{(\omega, m)}(u, t, s)$ by the differential equation:

$$\frac{\partial}{\partial t} f_\Gamma^{(\omega, m)}(u, t, s) = f_\Gamma^{(\omega, m)}(u, t, s) \int_0^s m \left(\widetilde{\frac{\partial}{\partial s'} \gamma^t(s')}, \widetilde{\frac{\partial}{\partial t} \gamma^t(s')} \right)_{\mathcal{H}_\omega(\gamma^t, s', u^t)} ds', \quad (2.16)$$

with initial condition $f_\Gamma^{(\omega, m)}(u, 0, s) = 1_E$, for each $s \in [0, 1]$. Note that the differential equation for $f_\Gamma^{(\omega, m)}$ is obtained from the differential equation for $e_\Gamma^{(\omega, m)}$, equation (2.12), by reversing the roles of s and t . Let $f_\Gamma^{(\omega, m)}(u, 1, 1) \doteq f_\Gamma^{(\omega, m)}(u)$. The following holds.

Theorem 2.29 (Non-abelian Fubini's Theorem, bundle form)

$$e_\Gamma^{(\omega, m)}(u) f_\Gamma^{(\omega, m)}(u) = 1.$$

Proof. In fact we show for every $t, s \in [0, 1]$:

$$e_\Gamma^{(\omega, m)}(u, t, s) f_\Gamma^{(\omega, m)}(u, t, s) = 1. \quad (2.17)$$

In the following put $e_\Gamma^{(\omega, m)}(u, t, s) = e(t, s)$. Let θ be the canonical left invariant 1-form in E (the Maurer-Cartan 1-form); see 2.6.1. Taking the t derivative of (2.12), we obtain:

$$\frac{\partial}{\partial t} \theta \left(\frac{\partial}{\partial s} e(t, s) \right) = m \left(\widetilde{\frac{\partial}{\partial t} \gamma_s(t)}, \widetilde{\frac{\partial}{\partial s} \gamma_s(t)} \right)_{\mathcal{H}_\omega(\gamma_s, t, u_s)}.$$

By (2.14) and the G -equivariance of m :

$$\partial(e(t, s)) \triangleright \frac{\partial}{\partial t} \theta \left(\frac{\partial}{\partial s} e(t, s) \right) = m \left(\widetilde{\frac{\partial}{\partial t} \gamma_s(t)}, \widetilde{\frac{\partial}{\partial s} \gamma_s(t)} \right)_{\mathcal{H}_\omega(\gamma^t, s, u^t)}.$$

We also have:

$$\begin{aligned} & \frac{\partial}{\partial s} \left(\partial(e(t, s)) \triangleright \theta \left(\frac{\partial}{\partial t} e(t, s) \right) \right) \\ &= \partial(e(t, s)) \triangleright \left(\partial \left(\theta \left(\frac{\partial}{\partial s} e(t, s) \right) \right) \triangleright \theta \left(\frac{\partial}{\partial t} e(t, s) \right) \right) + \partial(e(t, s)) \triangleright \frac{\partial}{\partial s} \left(\theta \left(\frac{\partial}{\partial t} e(t, s) \right) \right) \\ &= \partial(e(t, s)) \triangleright \left(\left[\theta \left(\frac{\partial}{\partial s} e(t, s) \right), \theta \left(\frac{\partial}{\partial t} e(t, s) \right) \right] + \frac{\partial}{\partial s} \theta \left(\frac{\partial}{\partial t} e(t, s) \right) \right) \\ &= \partial(e(t, s)) \triangleright \frac{\partial}{\partial t} \theta \left(\frac{\partial}{\partial s} e(t, s) \right). \end{aligned}$$

The second equation follows from the definition of a differential crossed module, and the third from the fact $d\theta(X, Y) = -[X, Y]$ for each $X, Y \in \mathfrak{e}$. Combining the two equations and integrating in s , with $e_\Gamma^{(\omega, m)}(u, t, 0) = 1_E$, we obtain:

$$\frac{\partial}{\partial t} e_\Gamma^{(\omega, m)}(u, t, s) = \left(\int_0^s m \left(\widetilde{\frac{\partial}{\partial t} \gamma_{s'}(t)}, \widetilde{\frac{\partial}{\partial s'} \gamma_{s'}(t)} \right)_{\mathcal{H}_\omega(\gamma^t, s', u^t)} ds' \right) e_\Gamma^{(\omega, m)}(u, t, s),$$

with initial condition $e_\Gamma^{(\omega, m)}(u, 0, s) = 1_E$, (set $t = 0$ in (2.12)), from which (2.17) follows as an immediate consequence. ■ Note that by using the Non-Abelian Fubini's Theorem, lemmas 2.26 and 2.27 follow directly from lemmas 2.24 and 2.25.

From the Non-Abelian Fubini's Theorem and 2.5.2 it follows that the two-dimensional holonomy of a categorical connection is covariant with respect to the action of the dihedral group $D_4 \cong \mathbb{Z}_2^2 \rtimes \mathbb{Z}_2$ of symmetries of the square; see 2.6.4.

2.6 Dependence of the categorical holonomy on a smooth family of squares

In this subsection we prove a fundamental result giving the variation of the 2-holonomy of a smooth family of 2-paths in terms of the 2-curvature, analogous to equation (2.13) for the variation of the 1-holonomy of a smooth family of 1-paths in terms of the curvature. Let $P \rightarrow M$ be a principal G -bundle over the smooth manifold M with a \mathcal{G} -categorical connection (ω, m) . Here $\mathcal{G} = (E \xrightarrow{\partial} G, \triangleright)$ is a Lie crossed module, where \triangleright is a Lie group left action of G on E by automorphisms. Let $\mathfrak{G} = (\partial: \mathfrak{e} \rightarrow \mathfrak{g}, \triangleright)$ be the associated differential crossed module.

Consider a smooth map $J: [0, 1]^3 \rightarrow M$. Put $J(t, s, x) = \Gamma^x(t, s)$, where $x, t, s \in [0, 1]$. Define $q(x) = J(0, 0, x)$, for each $x \in [0, 1]$. Choose $u \in P_{q(0)}$ and let $u(x) = \mathcal{H}_\omega(q, x, u)$. We want to analyse the dependence on x of the categorical holonomy $e_{\Gamma^x}^{(\omega, m)}(u(x), t, s)$, see equation (2.12). To this end, we now prove the following well known technical lemma, also appearing in [FMP1].

2.6.1 A well-known lemma

Let G be a Lie group. Consider a \mathfrak{g} -valued smooth function $V(s, x)$ defined on $[0, 1]^2$. Consider the following differential equation in G :

$$\frac{\partial}{\partial s} a(s, x) = a(s, x)V(s, x),$$

with initial condition $a(0, x) = 1_G$, for each $x \in [0, 1]$. We want to know $\frac{\partial}{\partial x} a(s, x)$.

Let θ be the canonical \mathfrak{g} -valued 1-form on G . Thus θ is left invariant and satisfies $\theta(A) = A$, for each $A \in \mathfrak{g}$, being defined uniquely by these properties. Also $d\theta(A, B) = -\theta([A, B])$, where $A, B \in \mathfrak{g}$. We have:

$$\frac{\partial}{\partial x} \theta \left(\frac{\partial}{\partial s} a(s, x) \right) = \frac{\partial}{\partial x} \theta(a(s, x)V(s, x)) = \frac{\partial}{\partial x} V(s, x).$$

On the other hand:

$$\begin{aligned} \frac{\partial}{\partial x} \theta \left(\frac{\partial}{\partial s} a(s, x) \right) &= da^*(\theta) \left(\frac{\partial}{\partial x}, \frac{\partial}{\partial s} \right) + \frac{\partial}{\partial s} a^*(\theta) \left(\frac{\partial}{\partial x} \right) + a^*(\theta) \left(\left[\frac{\partial}{\partial x}, \frac{\partial}{\partial s} \right] \right) \\ &= d\theta \left(\frac{\partial}{\partial x} a(s, x), \frac{\partial}{\partial s} a(s, x) \right) + \frac{\partial}{\partial s} \theta \left(\frac{\partial}{\partial x} a(s, x) \right). \end{aligned}$$

Therefore:

$$\theta \left(\frac{\partial}{\partial x} a(s, x) \right) + \int_0^s \left(d\theta \left(\frac{\partial}{\partial x} a(s', x), \frac{\partial}{\partial s'} a(s', x) \right) + \frac{\partial}{\partial x} V(s', x) \right) ds' = \theta \left(\frac{\partial}{\partial x} a(0, x) \right).$$

Since $\frac{\partial}{\partial x} a(0, x) = 0$ (due to the initial conditions) we have the following:

Lemma 2.30

$$\frac{\partial}{\partial x} a(s, x) = a(s, x) \int_0^s \left(-d\theta \left(\frac{\partial}{\partial x} a(s', x), \frac{\partial}{\partial s'} a(s', x) \right) + \frac{\partial}{\partial x} V(s', x) \right) ds',$$

for each $x, s \in [0, 1]$.

2.6.2 The relation between 2-curvature and categorical holonomy

The following main theorem is more general than the analogous result in [FMP1, SW2] since it is valid for any smooth homotopy J connecting two 2-paths Γ and Γ' , and in particular the basepoints of the 2-paths may vary with the parameter x . For this reason the proof is considerably longer, forcing several integrations by parts.

Theorem 2.31 *Let M be a smooth manifold. Let $\mathcal{G} = (\partial: E \rightarrow G, \triangleright)$ be a Lie crossed module. Let $P \rightarrow M$ be a principal G -bundle over M . Consider a \mathcal{G} -categorical connection (ω, m) on P . Let $J: [0, 1]^3 \rightarrow M$ be a smooth map. Let $J(t, s, x) = \Gamma^x(t, s) = \gamma_s^x(t) = \gamma^{x,t}(s)$; for each $t, s, x \in [0, 1]$. Define $q(x) = \Gamma^x(0, 0)$. Choose $u \in P_{q(0)}$, the fibre of P at $q(0)$. Let $u(x) = \mathcal{H}_\omega(q, x, u)$ and $u(x, s) = \mathcal{H}_\omega(\gamma^{x,0}, s, u(x))$, where $s, x \in [0, 1]$.*

Consider the map $(s, x) \in [0, 1]^2 \mapsto e_{\Gamma^x}(s) \in E$ defined by:

$$\frac{\partial}{\partial s} e_{\Gamma^x}(s) = e_{\Gamma^x}(s) \int_0^1 m \left(\frac{\partial}{\partial t} \widetilde{\gamma_s^x(t)}, \frac{\partial}{\partial s} \widetilde{\gamma_s^x(t)} \right)_{\mathcal{H}_\omega(\gamma_s^x, t, u(x, s))} dt, \quad (2.18)$$

with initial condition:

$$e_{\Gamma^x}(0) = 1_E, \text{ for each } x \in [0, 1], \quad (2.19)$$

Let $e_{\Gamma^x} = e_{\Gamma^x}(1)$. For each $x \in [0, 1]$, we have:

$$\begin{aligned} \frac{d}{dx} e_{\Gamma^x} &= e_{\Gamma^x} \int_0^1 \int_0^1 \mathcal{M} \left(\frac{\partial}{\partial x} \widetilde{\gamma_s^x(t)}, \frac{\partial}{\partial t} \widetilde{\gamma_s^x(t)}, \frac{\partial}{\partial s} \widetilde{\gamma_s^x(t)} \right)_{\mathcal{H}_\omega(\gamma_s^x, t, u(x, s))} dt ds \\ &\quad + e_{\Gamma^x} \int_0^1 m \left(\frac{\partial}{\partial n} \widetilde{\hat{\gamma}^x(n)}, \frac{\partial}{\partial x} \widetilde{\hat{\gamma}^x(n)} \right)_{\mathcal{H}_\omega(\hat{\gamma}^x, n, u(x))} dn, \end{aligned}$$

where $\hat{\gamma}^x = \partial\Gamma^x$, starting at $\Gamma^x(0, 0)$ and oriented clockwise. Here $\mathcal{M} \in \mathcal{A}^3(P, \mathfrak{e})$ is the categorical curvature 3-form of (ω, m) ; see 2.4.3.

Proof. Consider the smooth map $f: [0, 1]^3 \rightarrow P$ such that $f(x, s, t) = \mathcal{H}_\omega(\gamma_s^x, t, u(x, s))$, for each $x, s, t \in [0, 1]$. By definition we have:

$$\frac{\partial}{\partial t} f(x, s, t) = \frac{\partial}{\partial t} \widetilde{\gamma_s^x(t)}_{\mathcal{H}_\omega(\gamma_s^x, t, u(x, s))}$$

and therefore $\omega(\frac{\partial}{\partial t} f(x, s, t)) = 0$. We also have:

$$\left(\frac{\partial}{\partial s} f(x, s, t) \right)^H = \frac{\partial}{\partial s} \widetilde{\gamma_s^x(t)}_{\mathcal{H}_\omega(\gamma_s^x, t, u(x, s))}$$

and

$$\left(\frac{\partial}{\partial x} f(x, s, t) \right)^H = \frac{\partial}{\partial x} \widetilde{\gamma_s^x(t)}_{\mathcal{H}_\omega(\gamma_s^x, t, u(x, s))}.$$

Note also that $m(X, Y)$, $\Omega(X, Y)$ and $\mathcal{M}(X, Y, Z)$ vanish if either X, Y or Z is vertical.

By the 2-structure equation, see Proposition 2.18, and equation (2.6) it follows that (since \mathcal{M} is horizontal):

$$\begin{aligned}
& \int_0^1 \int_0^1 \mathcal{M} \left(\widetilde{\frac{\partial}{\partial x} \gamma_s^x(t)}, \widetilde{\frac{\partial}{\partial t} \gamma_s^x(t)}, \widetilde{\frac{\partial}{\partial s} \gamma_s^x(t)} \right)_{\mathcal{H}_\omega(\gamma_s^x, t, u(x, s))} dt ds \\
&= \int_0^1 \int_0^1 \mathcal{M} \left(\frac{\partial}{\partial x} f(x, s, t), \frac{\partial}{\partial t} f(x, s, t), \frac{\partial}{\partial s} f(x, s, t) \right) dt ds \\
&= \int_0^1 \int_0^1 dm \left(\frac{\partial}{\partial x} f(x, s, t), \frac{\partial}{\partial t} f(x, s, t), \frac{\partial}{\partial s} f(x, s, t) \right) dt ds \\
&\quad + \int_0^1 \int_0^1 \omega \left(\frac{\partial}{\partial x} f(x, s, t) \right) \triangleright m \left(\frac{\partial}{\partial t} f(x, s, t), \frac{\partial}{\partial s} f(x, s, t) \right) dt ds \\
&\quad - \int_0^1 \int_0^1 \omega \left(\frac{\partial}{\partial s} f(x, s, t) \right) \triangleright m \left(\frac{\partial}{\partial t} f(x, s, t), \frac{\partial}{\partial x} f(x, s, t) \right) dt ds.
\end{aligned}$$

Using Lemma 2.22 and integration by parts, we rewrite the integral in the last term:

$$\begin{aligned}
& \int_0^1 \omega \left(\frac{\partial}{\partial s} f(x, s, t) \right) \triangleright m \left(\frac{\partial}{\partial t} f(x, s, t), \frac{\partial}{\partial x} f(x, s, t) \right) dt \\
&= \int_0^1 \int_0^t \Omega \left(\frac{\partial}{\partial t'} f(x, s, t'), \frac{\partial}{\partial s} f(x, s, t') \right) dt' \triangleright m \left(\frac{\partial}{\partial t} f(x, s, t), \frac{\partial}{\partial x} f(x, s, t) \right) dt
\end{aligned}$$

or

$$\begin{aligned}
& \int_0^1 \Omega \left(\frac{\partial}{\partial t'} f(x, s, t'), \frac{\partial}{\partial s} f(x, s, t') \right) dt' \triangleright \int_0^1 m \left(\frac{\partial}{\partial t'} f(x, s, t'), \frac{\partial}{\partial x} f(x, s, t') \right) dt' \\
&- \int_0^1 \Omega \left(\frac{\partial}{\partial t} f(x, s, t), \frac{\partial}{\partial s} f(x, s, t) \right) \triangleright \left(\int_0^t m \left(\frac{\partial}{\partial t'} f(x, s, t'), \frac{\partial}{\partial x} f(x, s, t') \right) dt' \right) dt.
\end{aligned}$$

Using equation (2.2), we have for the final term:

$$\begin{aligned}
& \int_0^1 \Omega \left(\frac{\partial}{\partial t} f(x, s, t), \frac{\partial}{\partial s} f(x, s, t) \right) \triangleright \left(\int_0^t m \left(\frac{\partial}{\partial t'} f(x, s, t'), \frac{\partial}{\partial x} f(x, s, t') \right) dt' \right) dt \\
&= - \int_0^1 \int_0^t \Omega \left(\frac{\partial}{\partial t'} f(x, s, t'), \frac{\partial}{\partial x} f(x, s, t') \right) dt' \triangleright m \left(\frac{\partial}{\partial t} f(x, s, t), \frac{\partial}{\partial s} f(x, s, t) \right) dt \\
&= - \int_0^1 \omega \left(\frac{\partial}{\partial x} f(x, s, t) \right) \triangleright m \left(\frac{\partial}{\partial t} f(x, s, t), \frac{\partial}{\partial s} f(x, s, t) \right) dt \\
&\quad + \int_0^1 \int_0^s \Omega \left(\frac{\partial}{\partial s'} f(x, s', 0), \frac{\partial}{\partial x} f(x, s', 0) \right) ds' \triangleright m \left(\frac{\partial}{\partial t} f(x, s, t), \frac{\partial}{\partial s} f(x, s, t) \right) dt \\
&= - \int_0^1 \omega \left(\frac{\partial}{\partial x} f(x, s, t) \right) \triangleright m \left(\frac{\partial}{\partial t} f(x, s, t), \frac{\partial}{\partial s} f(x, s, t) \right) dt \\
&\quad + \int_0^1 \omega \left(\frac{\partial}{\partial x} f(x, s, 0) \right) \triangleright m \left(\frac{\partial}{\partial t} f(x, s, t), \frac{\partial}{\partial s} f(x, s, t) \right) dt.
\end{aligned}$$

where we have used Lemma 2.22 twice. Combining the previous equations, yields

$$\begin{aligned}
& \int_0^1 \int_0^1 \mathcal{M} \left(\widetilde{\frac{\partial}{\partial x} \gamma_s^x(t)}, \widetilde{\frac{\partial}{\partial t} \gamma_s^x(t)}, \widetilde{\frac{\partial}{\partial s} \gamma_s^x(t)} \right)_{\mathcal{H}_\omega(\gamma_s^x, t, u(x, s))} dt ds \\
&= \int_0^1 \int_0^1 dm \left(\frac{\partial}{\partial x} f(x, s, t), \frac{\partial}{\partial t} f(x, s, t), \frac{\partial}{\partial s} f(x, s, t) \right) dt ds \\
&- \int_0^1 \int_0^1 \Omega \left(\frac{\partial}{\partial t'} f(x, s, t'), \frac{\partial}{\partial s} f(x, s, t') \right) dt' \triangleright \int_0^1 m \left(\frac{\partial}{\partial t'} f(x, s, t'), \frac{\partial}{\partial x} f(x, s, t') \right) dt' ds \\
&- \int_0^1 \int_0^1 \omega \left(\frac{\partial}{\partial x} f(x, s, 0) \right) \triangleright m \left(\frac{\partial}{\partial t} f(x, s, t), \frac{\partial}{\partial s} f(x, s, t) \right) dt ds. \quad (2.20)
\end{aligned}$$

For the second term on the right hand side in the theorem, we obtain:

$$\begin{aligned}
& \int_0^1 m \left(\widetilde{\frac{\partial}{\partial n} \hat{\gamma}^x(n)}, \widetilde{\frac{\partial}{\partial x} \hat{\gamma}^x(n)} \right)_{\mathcal{H}_\omega(\hat{\gamma}^x, n, u(x))} dn \\
&= \int_0^1 m \left(\frac{\partial}{\partial s} f(x, s, 0), \frac{\partial}{\partial x} f(x, s, 0) \right) ds + \int_0^1 m \left(\frac{\partial}{\partial t} f(x, 1, t), \frac{\partial}{\partial x} f(x, 1, t) \right) dt \\
&- g^{-1} \triangleright \left(\int_0^1 m \left(\frac{\partial}{\partial s} f'(x, s, 1), \frac{\partial}{\partial x} f'(x, s, 1) \right) ds - \int_0^1 m \left(\frac{\partial}{\partial t} f(x, 0, t), \frac{\partial}{\partial x} f(x, 0, t) \right) dt \right), \quad (2.21)
\end{aligned}$$

where we have put $g(x, s) = \partial(e_{\Gamma^x}(s))$ and $f'(x, s, t) = \mathcal{H}_\omega(\gamma^{x, t}, s, \mathcal{H}_\omega(\gamma_0^x, t, u(x)))$; also $g = g(x, 1)$. Therefore $f(x, s, 1) = f'(x, s, 1)\partial(e_{\Gamma^x}(s))$ by the Non-Abelian Green's Theorem. Note that $f'(x, 0, t) = f(x, 0, t)$. We will be using the function f' again shortly.

Thus it remains to prove that $e_{\Gamma^x}^{-1} \frac{d}{dx} e_{\Gamma^x}$ is equal to the sum of the right hand sides of (2.20) and (2.21).

By Lemma 2.30, we have

$$\frac{d}{dx} e_{\Gamma^x} = e_{\Gamma^x} (A_x - B_x), \quad (2.22)$$

where

$$\begin{aligned}
A_x &= \int_0^1 \int_0^1 \frac{\partial}{\partial x} \left(m \left(\widetilde{\frac{\partial}{\partial t} \gamma_s^x(t)}, \widetilde{\frac{\partial}{\partial s} \gamma_s^x(t)} \right)_{\mathcal{H}_\omega(\gamma_s^x, t, u(x, s))} \right) dt ds \\
B_x &= \int_0^1 d\theta \left(\frac{\partial}{\partial x} e_{\Gamma^x}(s), \frac{\partial}{\partial s} e_{\Gamma^x}(s) \right) ds.
\end{aligned}$$

Let us analyse A_x and B_x separately. Using the well known equation:

$$d\alpha(X, Y, Z) = X\alpha(Y, Z) + Y\alpha(Z, X) + Z\alpha(X, Y) + \alpha(X, [Y, Z]) + \alpha(Y, [Z, X]) + \alpha(Z, [X, Y]),$$

valid for any smooth 2-form α in a manifold, and any three vector fields X, Y, Z in M , we obtain for A_x :

$$\begin{aligned} A_x &= \int_0^1 \int_0^1 \frac{\partial}{\partial x} m \left(\frac{\partial}{\partial t} f(x, s, t), \frac{\partial}{\partial s} f(x, s, t) \right) dt ds \\ &= \int_0^1 \int_0^1 dm \left(\frac{\partial}{\partial x} f(x, s, t), \frac{\partial}{\partial t} f(x, s, t), \frac{\partial}{\partial s} f(x, s, t) \right) dt ds \\ &\quad - \int_0^1 \int_0^1 \frac{\partial}{\partial t} m \left(\frac{\partial}{\partial s} f(x, s, t), \frac{\partial}{\partial x} f(x, s, t) \right) + \frac{\partial}{\partial s} m \left(\frac{\partial}{\partial x} f(x, s, t), \frac{\partial}{\partial t} f(x, s, t) \right) dt ds \end{aligned}$$

or

$$\begin{aligned} A_x &= \int_0^1 \int_0^1 dm \left(\frac{\partial}{\partial x} f(x, s, t), \frac{\partial}{\partial t} f(x, s, t), \frac{\partial}{\partial s} f(x, s, t) \right) dt ds \quad (2.23) \\ &\quad + \int_0^1 m \left(\frac{\partial}{\partial s} f(x, s, 0), \frac{\partial}{\partial x} f(x, s, 0) \right) ds + \int_0^1 m \left(\frac{\partial}{\partial t} f(x, 1, t), \frac{\partial}{\partial x} f(x, 1, t) \right) dt \\ &\quad - \int_0^1 m \left(\frac{\partial}{\partial t} f(x, 0, t), \frac{\partial}{\partial x} f(x, 0, t) \right) dt - \int_0^1 m \left(\frac{\partial}{\partial s} f(x, s, 1), \frac{\partial}{\partial x} f(x, s, 1) \right) ds. \end{aligned}$$

Recall that $g(x, s) = \partial(e_{\Gamma^x}(s))$ and $f'(x, s, t) = \mathcal{H}_\omega(\gamma^{x,t}, s, \mathcal{H}_\omega(\gamma_0^x, t, u(x)))$, and the relation $f(x, s, 1) = f'(x, s, 1)\partial(e_{\Gamma^x}(s))$. We thus have:

$$\omega \left(\frac{\partial}{\partial s} f'(x, s, 1) \right) = \omega \left(\frac{\partial}{\partial s} (f(x, s, 1)g^{-1}(x, s)) \right),$$

which since $\frac{\partial}{\partial s} f'(x, s, 1)$ is horizontal implies, by using the Leibniz rule and the fact that ω is a connection 1-form, that:

$$g(x, s)\omega \left(\frac{\partial}{\partial s} f(x, s, 1) \right) g^{-1}(x, s) + g(x, s)\frac{\partial}{\partial s} g^{-1}(x, s) = 0.$$

Analogously (this will be used later):

$$\begin{aligned} g^{-1}(x, s)\omega \left(\frac{\partial}{\partial x} (\mathcal{H}_\omega(\gamma^{x,1}, s, u(x)\gamma_0^x)) \right) g(x, s) \\ = -g^{-1}(x, s)\frac{\partial}{\partial x} g(x, s) + \omega \left(\frac{\partial}{\partial x} (u(x, s)\gamma_s^x) \right), \end{aligned}$$

which is the same as:

$$\frac{\partial}{\partial x} g(x, s) = g(x, s)\omega \left(\frac{\partial}{\partial x} f(x, s, 1) \right) - \omega \left(\frac{\partial}{\partial x} f'(x, s, 1) \right) g(x, s).$$

The very last term R of (2.23) can be simplified as follows (since m is horizontal and G -equivariant):

$$\begin{aligned}
R &= - \int_0^1 m \left(\frac{\partial}{\partial s} f(x, s, 1), \frac{\partial}{\partial x} f(x, s, 1) \right) ds \\
&= - \int_0^1 g^{-1}(x, s) \triangleright m \left(\frac{\partial}{\partial s} f'(x, s, 1), \frac{\partial}{\partial x} f'(x, s, 1) \right) ds \\
&= -g^{-1}(x, 1) \triangleright \int_0^1 m \left(\frac{\partial}{\partial s} f'(x, s, 1), \frac{\partial}{\partial x} f'(x, s, 1) \right) ds \\
&\quad + \int_0^1 \int_0^s \frac{\partial}{\partial s} g^{-1}(x, s) \triangleright m \left(\frac{\partial}{\partial s'} f'(x, s', 1), \frac{\partial}{\partial x} f'(x, s', 1) \right) ds' ds;
\end{aligned}$$

(the penultimate equation follows from integrating by parts). Therefore:

$$\begin{aligned}
R &= -g^{-1}(x, 1) \triangleright \int_0^1 m \left(\frac{\partial}{\partial s} f'(x, s, 1), \frac{\partial}{\partial x} f'(x, s, 1) \right) ds \\
&\quad - \int_0^1 \int_0^s \omega \left(\frac{\partial}{\partial s} f(x, s, 1) \right) g^{-1}(x, s) \triangleright m \left(\frac{\partial}{\partial s'} f'(x, s', 1), \frac{\partial}{\partial x} f(x, s', 1) \right) ds' ds.
\end{aligned} \tag{2.24}$$

We now analyse B_x , for each $x \in [0, 1]$. We have:

$$\begin{aligned}
B_x &= d\theta \left(e_{\Gamma^x}^{-1}(s) \frac{\partial}{\partial x} e_{\Gamma^x}(s), e_{\Gamma^x}^{-1}(s) \frac{\partial}{\partial s} e_{\Gamma^x}(s) \right) \\
&= - \left[e_{\Gamma^x}^{-1}(s) \frac{\partial}{\partial x} e_{\Gamma^x}(s), e_{\Gamma^x}^{-1}(s) \frac{\partial}{\partial s} e_{\Gamma^x}(s) \right] \\
&= - \left(g^{-1}(x, s) \frac{\partial}{\partial x} g(x, s) \right) \triangleright \left(e_{\Gamma^x}^{-1}(s) \frac{\partial}{\partial s} e_{\Gamma^x}(s) \right) \\
&= -\omega \left(\frac{\partial}{\partial x} f(x, s, 1) \right) \triangleright \int_0^1 m \left(\frac{\partial}{\partial t} f(x, s, t), \frac{\partial}{\partial s} f(x, s, t) \right) dt \\
&\quad + \left(g^{-1}(x, s) \omega \left(\frac{\partial}{\partial x} f'(x, s, 1) \right) g(x, s) \right) \triangleright \int_0^1 m \left(\frac{\partial}{\partial t} f(x, s, t), \frac{\partial}{\partial s} f(x, s, t) \right) dt.
\end{aligned}$$

By using Lemma 2.22, this may be rewritten as $B_x = C_x + C'_x$, where

$$\begin{aligned}
C_x &= - \int_0^1 \Omega \left(\frac{\partial}{\partial t} f(x, s, t), \frac{\partial}{\partial x} f(x, s, t) \right) dt \triangleright \int_0^1 m \left(\frac{\partial}{\partial t} f(x, s, t), \frac{\partial}{\partial s} f(x, s, t) \right) dt \\
&\quad - \int_0^s \Omega \left(\frac{\partial}{\partial s'} f(x, s', 0), \frac{\partial}{\partial x} f(x, s', 0) \right) ds' \triangleright \int_0^1 m \left(\frac{\partial}{\partial t} f(x, s, t), \frac{\partial}{\partial s} f(x, s, t) \right) dt
\end{aligned}$$

and

$$\begin{aligned}
C'_x = & \left(g^{-1}(x, s) \left(\int_0^s \Omega \left(\frac{\partial}{\partial s'} f'(x, s', 1), \frac{\partial}{\partial x} f'(x, s', 1) \right) ds' \right) g(x, s) \right) \triangleright \\
& \int_0^1 m \left(\frac{\partial}{\partial t} f(x, s, t), \frac{\partial}{\partial s} f(x, s, t) \right) dt \\
& + \left(g^{-1}(x, s) \left(\int_0^1 \Omega \left(\frac{\partial}{\partial t} f(x, 0, t), \frac{\partial}{\partial x} f(x, 0, t) \right) dt \right) g(x, s) \right) \triangleright \\
& \int_0^1 m \left(\frac{\partial}{\partial t} f(x, s, t), \frac{\partial}{\partial s} f(x, s, t) \right) dt,
\end{aligned}$$

Again using $\partial(m) = \Omega$ and $\partial(u) \triangleright v = [u, v] = -[v, u] = -\partial(v) \triangleright u$; for each $u, v \in \mathfrak{e}$, together with $\partial(m) = \Omega$ and Lemma 2.22, for all but the second term of the right hand side of the previous equation, we obtain:

$$\begin{aligned}
B_x = & \int_0^1 \left(\int_0^1 \Omega \left(\frac{\partial}{\partial t} f(x, s, t), \frac{\partial}{\partial s} f(x, s, t) \right) dt \triangleright \int_0^1 m \left(\frac{\partial}{\partial t} f(x, s, t), \frac{\partial}{\partial x} f(x, s, t) \right) dt \right) ds. \\
& - \int_0^1 \int_0^1 \omega \left(\frac{\partial}{\partial x} f(x, s, 0) \right) \triangleright m \left(\frac{\partial}{\partial t} f(x, s, t), \frac{\partial}{\partial s} f(x, s, t) \right) dt ds \\
& - \int_0^1 \int_0^s \omega \left(\frac{\partial}{\partial s} f(x, s, 1) \right) g^{-1}(x, s) \triangleright m \left(\frac{\partial}{\partial s'} f'(x, s', 1), \frac{\partial}{\partial x} f'(x, s', 1) \right) ds' ds \\
& - \int_0^1 \int_0^1 \omega \left(\frac{\partial}{\partial s} f(x, s, 1) \right) g^{-1}(x, s) \triangleright m \left(\frac{\partial}{\partial t} f(x, 0, t), \frac{\partial}{\partial x} f(x, 0, t) \right) dt ds
\end{aligned} \tag{2.25}$$

Finally, since (given that ω is a connection 1-form):

$$\begin{aligned}
\omega \left(\frac{\partial}{\partial s} f(x, s, 1) \right) g^{-1}(x, s) &= g^{-1}(x, s) \omega \left(\frac{\partial}{\partial s} f(x, s, 1) g^{-1}(x, s) \right) \\
&= g^{-1}(x, s) \omega \left(\frac{\partial}{\partial s} f'(x, s, 1) - f(x, s, 1) \frac{\partial}{\partial s} g^{-1}(x, s) \right) \\
&= -g^{-1}(x, s) \omega \left(f(x, s, 1) \frac{\partial}{\partial s} g^{-1}(x, s) \right) \\
&= -\frac{\partial}{\partial s} g^{-1}(x, s),
\end{aligned}$$

the last term R' of the previous expression is rewritten as follows:

$$\begin{aligned}
R' &= - \int_0^1 \int_0^1 \omega \left(\frac{\partial}{\partial s} f(x, s, 1) \right) g^{-1}(x, s) \triangleright m \left(\frac{\partial}{\partial t} f(x, 0, t), \frac{\partial}{\partial x} f(x, 0, t) \right) ds dt \\
&= \int_0^1 \int_0^1 \frac{\partial}{\partial s} g^{-1}(x, s) \triangleright m \left(\frac{\partial}{\partial t} f(x, 0, t), \frac{\partial}{\partial x} f(x, 0, t) \right) ds dt,
\end{aligned}$$

or

$$R' = g^{-1}(x) \triangleright \int_0^1 m \left(\frac{\partial}{\partial t} f(x, 0, t), \frac{\partial}{\partial x} f(x, 0, t) \right) dt - \int_0^1 m \left(\frac{\partial}{\partial t} f(x, 0, t), \frac{\partial}{\partial x} f(x, 0, t) \right) dt, \quad (2.26)$$

where we have put $g(x) = g(x, 1)$. Combining $A_x - B_x$ from equations (2.23), (2.24), (2.25), (2.26), four terms cancel and the remaining terms are equal to the sum of the right hand sides of (2.20) and (2.21). This finishes the proof of Theorem 2.31. ■

2.6.3 Invariance under thin homotopy

From Theorem 2.31 and the fact that the horizontal lift $X \mapsto \tilde{X}$ of vector fields on M defines a linear map $\mathcal{X}(M) \rightarrow \mathcal{X}(P)$ we obtain the following:

Corollary 2.32 *Let M be a smooth manifold. Let also $\mathcal{G} = (\partial: E \rightarrow G, \triangleright)$ be a Lie crossed module. Let $P \rightarrow M$ be a principal G -bundle over M , and consider a \mathcal{G} -categorical connection (ω, m) on P . If Γ and Γ' are rank-2 homotopic (see Definition 2.11) 2-paths $[0, 1]^2 \rightarrow M$ then $e_{\Gamma}^{(\omega, m)}(u, t, s) = e_{\Gamma'}^{(\omega, m)}(u, t, s)$, whenever $u \in P_{\Gamma(0,0)}$, the fibre of P at $\Gamma(0,0) = \Gamma'(0,0)$, and for each $t, s \in [0, 1]$.*

2.6.4 A (dihedral) double groupoid map

Let P be a principal G bundle over M . We define a double groupoid $\mathcal{D}^2(P)$ whose set of objects is M , and whose set of morphisms $x \rightarrow y$ is given by all right G -equivariant maps $a: P_x \rightarrow P_y$. A 2-morphism is given by a square of the form:

$$\begin{array}{ccc} P_z & \xrightarrow{d} & P_w \\ c \uparrow & f & \uparrow b \\ P_x & \xrightarrow{a} & P_y \end{array} \quad (2.27)$$

where $x, y, z, w \in M$ and a, b, c, d are right G -equivariant maps. Finally $f: P_x \rightarrow P_y$ is a smooth map such that $f(ug) = g^{-1} \triangleright f(u)$ for each $u \in P_x$ and $g \in G$, satisfying $(b \circ a)(u) \partial(f(u)) = (d \circ c)(u)$, for each $u \in P_x$. The horizontal and vertical compositions are as in 2.5.2. We also have an action of the dihedral group $D_4 \cong \mathbb{Z}_2^2 \rtimes \mathbb{Z}_2$ of the 2-cube given by the horizontal and vertical reversions, and such that the interchange of coordinates is accomplished by the move $f \mapsto f^{-1}$. As a corollary of the discussion in the last two subsections it follows:

Theorem 2.33 *Whenever the principal G -bundle $P \rightarrow M$ is equipped with a categorical connection (ω, m) , the holonomy and categorical holonomy maps \mathcal{H}_{ω} and $e^{(\omega, m)}$ define a double groupoid morphism $\mathcal{H}: \mathcal{S}_2(M) \rightarrow \mathcal{D}^2(P)$, where $\mathcal{S}_2(M)$ is the thin fundamental double groupoid of M . Given a dihedral group*

element $r \in D_4$ we have

$${}^{(\omega, m)}\mathcal{H}(\Gamma \circ r^{-1}) = r \left({}^{(\omega, m)}\mathcal{H}(\Gamma) \right).$$

3 Cubical \mathcal{G} -2-bundles with connection

3.1 Definition of a cubical \mathcal{G} -2-bundle

Recall the conventions introduced in 2.1.1 and 2.2.2.

Let M be a smooth manifold. Let $\mathcal{U} = \{U_i\}_{i \in \mathcal{J}}$ be an open cover of M . From this we can define a cubical set $C(M, \mathcal{U})$. For each positive integer n the set $C^n(M, \mathcal{U})$ of n -cubes of $C(M, \mathcal{U})$ is given by all pairs (x, R) , where R is an assignment of an element $U_v^R \in \mathcal{U}$ to each vertex v of D^n , such that the intersection

$$U^R = \bigcap_{\text{vertices } v \text{ of } D^n} U_v^R$$

is non-empty, and $x \in U^R$. The face maps $\partial_i^\pm: C^n(M, \mathcal{U}) \rightarrow C^{n-1}(M, \mathcal{U})$ where $i \in \{1, \dots, n\}$ and $n = 1, 2, \dots$, are defined by

$$\partial_i^\pm(x, R) = (x, R \circ \delta_i^\pm).$$

Analogously, the degeneracies are given by:

$$\epsilon_i(x, R) = (x, R \circ \sigma_i).$$

The cubical set $C(M, \mathcal{U})$ is clearly a cubical object in the category of manifolds, in other words a cubical manifold. Given an $x \in M$, the cubical set $C(M, \mathcal{U}, x)$ is given by all the cubes of $C(M, \mathcal{U})$ whose associated element of M is x .

Definition 3.1 (Cubical \mathcal{G} -2-bundle) *Let $\mathcal{G} = (\partial: E \rightarrow G, \triangleright)$ be a Lie crossed module. Let $\mathcal{N}(\mathcal{G})$ be the cubical nerve of \mathcal{G} ; see [BHS] and 2.2.2, which is a cubical manifold. Let M be a smooth manifold and $\mathcal{U} = \{U_i\}_{i \in \mathcal{J}}$ be an open cover of M . A cubical \mathcal{G} -2-bundle over (M, \mathcal{U}) is given by a map $C(M, \mathcal{U}) \rightarrow \mathcal{N}(\mathcal{G})$ of cubical manifolds.*

Unpacking this definition, we see that a cubical \mathcal{G} -2-bundle is specified by smooth maps $\phi_{ij}: U_i \cap U_j \rightarrow G$, where $U_i, U_j \in \mathcal{U}$ have a non-empty intersection, and also by smooth maps $\psi_{ijkl}: U_i \cap U_j \cap U_k \cap U_l \rightarrow E$, where $U_i, U_j, U_k, U_l \in \mathcal{U}$ have a non-empty intersection, such that:

1. *We have $\partial(\psi_{ijkl})^{-1}\phi_{ij}\phi_{jl} = \phi_{ik}\phi_{kl}$ in $U_{ijkl} \doteq U_i \cap U_j \cap U_k \cap U_l$. In other words, putting $\phi_{ij} = X_2^-(\mathbf{c}_2)$, $\phi_{ik} = X_1^-(\mathbf{c}_2)$, $\phi_{kl} = X_2^+(\mathbf{c}_2)$, $\phi_{jl} = X_1^+(\mathbf{c}_2)$ and $e(\mathbf{c}_2) = \psi_{ijkl}$ yields a flat \mathcal{G} -colouring $\mathbf{c}_2 = (\psi, \phi)_{ijkl}$ of D^2 , for each $x \in U_{ijkl}$.*

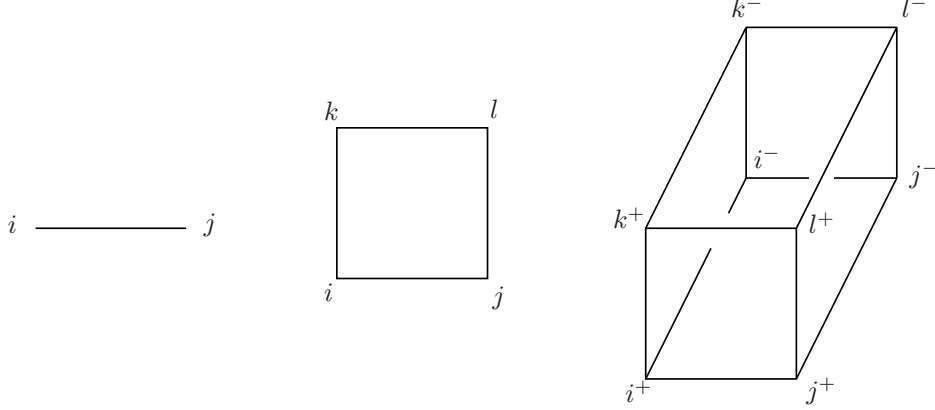

Figure 1: Label conventions in Definition 3.1.

2. Given $i^\pm, j^\pm, k^\pm, l^\pm \in \mathcal{J}$ with $U_{i^-j^-k^-l^-} \cap U_{i^+j^+k^+l^+} \neq \emptyset$, and putting

$$e_3^\pm(\mathbf{c}_3) = (\psi, \phi)_{i^\pm j^\pm k^\pm l^\pm}, \quad e_1^-(\mathbf{c}_3) = (\psi, \phi)_{i^-k^-i^+k^+}, \quad e_1^+(\mathbf{c}_3) = (\psi, \phi)_{j^-l^-j^+l^+},$$

$$e_2^-(\mathbf{c}_3) = (\psi, \phi)_{i^-j^-i^+j^+} \text{ and } e_2^+(\mathbf{c}_3) = (\psi, \phi)_{k^-l^-k^+l^+}$$

yields a flat \mathcal{G} -colouring \mathbf{c}_3 of D^3 in $U_{i^-j^-k^-l^-} \cap U_{i^+j^+k^+l^+}$.

3. $\phi_{ii} = 1_G$ in U_i for all $i \in \mathcal{J}$.

4. $\psi_{iijj} = \psi_{ijij} = 1_E$ in U_{ij}

See Figure 1 for our conventions in labelling the vertices of D^2 and D^3 .

The previous definition is therefore a cubical counterpart of the simplicial definition of a \mathcal{G} -2-bundle (and non-abelian gerbe) appearing for example in [BrMe, ACG, BS1, BS2, SW3].

Remark 3.2 Note that in Definition 3.1 the word bundle is used in the same sense as when one defines a principal bundle in terms of its transition functions, without reference to a total space; we are following [H, MP, P]. For a discussion of the concept of total space of a non-abelian gerbe, see [RS, Bar, Wo].

Definition 3.3 (Dihedral cubical \mathcal{G} -2-bundles) Recall that the cubical sets $C(M, \mathcal{U})$ and $\mathcal{N}(\mathcal{G})$ are dihedral; see 2.1.1. Therefore we can restrict our definition of a cubical \mathcal{G} -2-bundle and only allow dihedral cubical maps $C(M, \mathcal{U}) \rightarrow \mathcal{N}(\mathcal{G})$ which gives the definition of a dihedral cubical \mathcal{G} -2-bundle. Explicitly, a cubical \mathcal{G} -2-bundle is said to be dihedral if the maps $\phi_{ij}: U_{ij} \rightarrow G$ and $\psi_{ijkl}: U_{ijkl} \rightarrow E$ satisfy the following extra conditions:

1. We have $\phi_{ji} = \phi_{ij}^{-1}$ in U_{ij} for all $i, j \in \mathcal{J}$.

2. We have $\psi_{ikjl} = \psi_{ijkl}^{-1}$, $\psi_{jilk} = \phi_{ij} \triangleright \psi_{ijkl}^{-1}$ and $\psi_{klij} = \phi_{ik} \triangleright \psi_{ijkl}^{-1}$ in U_{ijkl} .

3.2 Connections in cubical \mathcal{G} -2-bundles

Let $\mathcal{G} = (\partial: E \rightarrow G, \triangleright)$ be a Lie crossed module, where \triangleright is a Lie group left action of G on E by automorphisms. Let also $\mathfrak{G} = (\partial: \mathfrak{e} \rightarrow \mathfrak{g}, \triangleright)$ be the associated differential crossed module.

Definition 3.4 (Connection in a cubical \mathcal{G} -2-bundle) *Let M be a smooth manifold with an open cover $\mathcal{U} = \{U_i\}_{i \in \mathcal{J}}$. A connection in a cubical \mathcal{G} -2-bundle over (M, \mathcal{U}) is given by:*

- For any $i \in \mathcal{J}$ a local connection pair (A_i, B_i) defined in U_i ; in other words $A_i \in \mathcal{A}^1(U_i, \mathfrak{g})$, $B_i \in \mathcal{A}^2(U_i, \mathfrak{e})$ and $\partial(B_i) = dA_i + \frac{1}{2}A_i \wedge^{\text{ad}} A_i = \Omega_{A_i}$.
- For any ordered pair (i, j) an \mathfrak{e} -valued 1-form η_{ij} in U_{ij} .

The conditions that should hold are:

1. For any $i \in \mathcal{J}$ we have $\eta_{ii} = 0$.
2. For any $i, j \in \mathcal{J}$ we have:

$$\begin{aligned} A_j &= \phi_{ij}^{-1} (A_i + \partial(\eta_{ij})) \phi_{ij} + \phi_{ij}^{-1} d\phi_{ij}, \\ B_j &= \phi_{ij}^{-1} \triangleright \left(B_i + d\eta_{ij} + \frac{1}{2}\eta_{ij} \wedge^{\text{ad}} \eta_{ij} + A_i \wedge^{\triangleright} \eta_{ij} \right). \end{aligned}$$

3. For any $i, j, k, l \in \mathcal{J}$ we have:

$$\begin{aligned} \eta_{ik} + \phi_{ik} \triangleright \eta_{kl} - \phi_{ik} \phi_{kl} \phi_{jl}^{-1} \triangleright \eta_{jl} - \phi_{ik} \phi_{kl} \phi_{jl}^{-1} \phi_{ij}^{-1} \triangleright \eta_{ij} \\ = \psi_{ijkl}^{-1} d\psi_{ijkl} + \psi_{ijkl}^{-1} (A_i \wedge^{\triangleright} \psi_{ijkl}). \end{aligned}$$

The equivalence of cubical \mathcal{G} -2-bundles with connection will be dealt with in subsection 4.3.

Definition 3.5 (Dihedral connection) *If a cubical \mathcal{G} -2-bundle is dihedral, then a connection in it is said to be dihedral if the following extra condition holds:*

$$\eta_{ji} = -\phi_{ij}^{-1} \triangleright \eta_{ij}, \text{ for each } i, j \in \mathcal{J};$$

therefore, condition 3 of the previous definition can be written as:

$$\eta_{ik} + \phi_{ik} \triangleright \eta_{kl} + \phi_{ik} \phi_{kl} \triangleright \eta_{lj} + \phi_{ik} \phi_{kl} \phi_{lj} \triangleright \eta_{ji} = \psi_{ijkl}^{-1} d\psi_{ijkl} + \psi_{ijkl}^{-1} (A_i \wedge^{\triangleright} \psi_{ijkl}).$$

4 Non-abelian integral calculus based on a crossed module

4.1 Path-ordered exponential and surface-ordered exponential

We continue with the notation and results of subsections 2.5 and 2.6. Alternative direct derivations of some of the following results appear in [BS1, SW1, SW2, SW3].

Let M be a manifold, and let G be a Lie group with Lie algebra \mathfrak{g} . Let $\gamma: [0, 1] \rightarrow M$ be a piecewise smooth map. Let $A \in \mathcal{A}^1(M, \mathfrak{g})$ be a \mathfrak{g} -valued 1-form in M . We define, as is usual, the path ordered exponential ${}^A g\gamma(t) = \mathcal{P} \exp \left(\int_0^t A \left(\frac{d}{dt'} \gamma(t') \right) dt' \right)$ to be the solution of the differential equation:

$$\frac{d}{dt} {}^A g\gamma(t) = {}^A g\gamma(t) A \left(\frac{d}{dt} \gamma(t) \right),$$

with initial condition ${}^A g\gamma(0) = 1_G$; see [Ch]. Put ${}^A g\gamma \doteq {}^A g\gamma(1) = \mathcal{P} \exp \left(\int_0^1 A \left(\frac{d}{dt} \gamma(t) \right) dt \right)$.

We immediately get that ${}^A g_{\gamma\gamma'} = {}^A g_\gamma {}^A g_{\gamma'}$, and also ${}^A g_{\gamma^{-1}} = ({}^A g_\gamma)^{-1}$. Here γ and γ' are piecewise smooth maps with $\gamma(1) = \gamma'(0)$.

Consider the trivial bundle $P = M \times G$ over M . Given $A \in \mathcal{A}^1(M, \mathfrak{g})$ there exists a unique connection 1-form ω_A in the trivial bundle P for which $A = \zeta^*(\omega_A)$, where $\zeta(x) = (x, 1_G)$ for each $x \in M$. We then have that:

$$\zeta(\gamma(t)) = \mathcal{H}_{\omega_A}(\gamma, t, \zeta(\gamma(0))) \mathcal{P} \exp \left(\int_0^t A \left(\frac{d}{dt'} \gamma(t') \right) dt' \right).$$

Let $\mathcal{G} = (\partial: E \rightarrow G, \triangleright)$ be a Lie crossed module and let $\mathfrak{G} = (\partial: \mathfrak{e} \rightarrow \mathfrak{g}, \triangleright)$ be the associated differential crossed module. As before, if we have $B \in \mathcal{A}^2(M, \mathfrak{e})$ with $\partial(B) = \Omega_A = dA + \frac{1}{2} A \wedge^{\text{ad}} A$ we define

$${}^{(A,B)} e_\Gamma(t, s) = \mathcal{S} \exp \left(\int_0^s \int_0^t B \left(\frac{\partial}{\partial t'} \gamma_{s'}(t'), \frac{\partial}{\partial s'} \gamma_{s'}(t') \right) dt' ds' \right)$$

as being the solution of the differential equation:

$$\frac{\partial}{\partial s} {}^{(A,B)} e_\Gamma(t, s) = {}^{(A,B)} e_\Gamma(t, s) \int_0^t \left({}^A g_{\gamma^0(s)} {}^A g_{\gamma_s(t')} \right) \triangleright B \left(\frac{\partial}{\partial t'} \gamma_s(t'), \frac{\partial}{\partial s} \gamma_s(t') \right) dt'$$

with initial conditions

$${}^{(A,B)} e_\Gamma(t, 0) = 1_E, \text{ for each } t \in [0, 1].$$

Put ${}^{(A,B)} e_\Gamma = {}^{(A,B)} e_\Gamma(1, 1)$. We can equivalently define the surface ordered exponential by the differential equation:

$$\frac{\partial}{\partial t} {}^{(A,B)} e_\Gamma(t, s) = \left(\int_0^s \left({}^A g_{\gamma_0(t)} {}^A g_{\gamma^t(s')} \right) \triangleright B \left(\frac{\partial}{\partial t} \gamma_{s'}(t), \frac{\partial}{\partial s'} \gamma_{s'}(t) \right) ds' \right) {}^{(A,B)} e_\Gamma(t, s)$$

with initial conditions

$${}^{(A,B)}e_\Gamma(0, s) = 1_E, \text{ for each } s \in [0, 1];$$

see the proof of Theorem 2.29 and below.

As before, there exists a unique categorical connection $(\omega_A, m_{A,B})$ in the trivial bundle $P = M \times G$ for which $A = \zeta^*(\omega_A)$ and $B = \zeta^*(m_{A,B})$. We have that ${}^{(A,B)}e_\Gamma(t, s) = {}^{(\omega_A, m_{A,B})}e_\Gamma(\zeta(\Gamma(0,0)), t, s)$, see 2.5.3. The following follows immediately from the Non-Abelian Green's Theorem 2.23.

Theorem 4.1 (Non-abelian Green's Theorem, elementary form) *Consider a 2-square $\Gamma: [0, 1]^2 \rightarrow M$. Put $X_\Gamma = g_{x_\Gamma}^A$, $Y_\Gamma = g_{y_\Gamma}^A$, $Z_\Gamma = g_{z_\Gamma}^A$ and $W_\Gamma = g_{w_\Gamma}^A$; see 2.5.2 for this notation. We have that:*

$$\partial \left({}^{(A,B)}e_\Gamma \right)^{-1} X_\Gamma Y_\Gamma = Z_\Gamma W_\Gamma.$$

The following follows from theorems 2.24 and 2.26. See 2.1.1 and subsection 2.3.

Theorem 4.2 *Consider the map $\mathcal{H} : C^2(M) \rightarrow \mathcal{D}^2(\mathcal{G})$ such that:*

$$\begin{array}{ccc} * & \xrightarrow{W_\Gamma^A} & * \\ {}^{(A,B)}\mathcal{H}(\Gamma) = & \begin{array}{c} \uparrow \\ Z_\Gamma^A \end{array} & \begin{array}{c} \uparrow \\ Y_\Gamma^A \end{array} \\ & \xrightarrow{X_\Gamma^A} & * \end{array}$$

Then ${}^{(A,B)}\mathcal{H}(\Gamma \circ_h \Gamma') = {}^{(A,B)}\mathcal{H}(\Gamma) \circ_h {}^{(A,B)}\mathcal{H}(\Gamma')$ and ${}^{(A,B)}\mathcal{H}(\Gamma \circ_v \Gamma') = {}^{(A,B)}\mathcal{H}(\Gamma) \circ_v {}^{(A,B)}\mathcal{H}(\Gamma')$, whenever the compositions of $\Gamma, \Gamma': [0, 1]^2 \rightarrow M$ are well defined.

Passing to the quotient $\mathcal{S}_2(M)$ of $C_r^2(M)$ under thin homotopy it follows, by using Theorem 2.31 and Corollary 2.32, that:

Theorem 4.3 *The map $\mathcal{H} : \mathcal{S}_2(M) \rightarrow \mathcal{D}^2(\mathcal{G})$ defined in the previous theorem is a morphism of double groupoids with thin structure.*

The following result is a consequence of Theorem 2.33.

Theorem 4.4 (Non-abelian Fubini's Theorem) *The map $\mathcal{H} : C^2(M) \rightarrow \mathcal{D}^2(\mathcal{G})$ preserves the action of the dihedral group D_4 of the square. Concretely for any element r of D_4 we have*

$${}^{(A,B)}\mathcal{H}(\Gamma \circ r^{-1}) = r({}^{(A,B)}\mathcal{H}(\Gamma)),$$

for each smooth map $\Gamma: [0, 1]^2 \rightarrow M$.

This follows from the fact that $\mathcal{H}^{(A,B)}$ preserves horizontal and vertical reversions and moreover interchanges of coordinates, which generate the dihedral group $D_4 \cong \mathbb{Z}_2^2 \rtimes S_2$ of the square.

We finish this subsection with the following important theorem:

Theorem 4.5 *Let (A, B) be a local connection pair in M , by which as usual we mean $A \in \mathcal{A}^1(M, \mathfrak{g})$, $B \in \mathcal{A}^2(M, \mathfrak{e})$ and $\partial(B) = \Omega_A = dA + \frac{1}{2}A \wedge^{\text{ad}} A$. Let $C = dB + A \wedge^\triangleright B$ be the 2-curvature 3-form of (A, B) as in 2.4.3 and 2.4.4. Let $J: [0, 1]^3 \rightarrow M$ be a smooth map such that $J^*(C) = 0$. Then the colouring T of D^3 such that:*

$$T \circ \delta_i^\pm = \mathcal{H}^{(A,B)}(\partial_i^\pm J), \quad i = 1, 2, 3$$

is flat; see 2.2.2 and 2.1.1.

Proof. This follows from the construction in this subsection and Theorem 2.31. Note the form (2.5) for the homotopy addition equation (2.4). ■

4.2 1-Gauge transformations

Let M be a smooth manifold. Let (A, B) and (A', B') be local connection pairs defined in M . For the time being we will drop the index i for the open cover and take A and B to be globally defined on M . We will return to the general case in the next section. In other words $A, A' \in \mathcal{A}^1(M, \mathfrak{g})$ and $B, B' \in \mathcal{A}^2(M, \mathfrak{e})$ are such that $\partial(B) = \Omega_A = dA + \frac{1}{2}A \wedge^{\text{ad}} A$ and $\partial(B') = \Omega_{A'}$. Let $\eta \in \mathcal{A}^1(M, \mathfrak{e})$ be such that:

$$A' = A + \partial(\eta)$$

and

$$B' = B + d\eta + \frac{1}{2}\eta \wedge^{\text{ad}} \eta + A \wedge^\triangleright \eta.$$

Given a smooth path $\gamma: [0, 1] \rightarrow M$, define the following 2-square in \mathcal{G} :

$$\tau_A^{(1_G, \eta)}(\gamma) = \begin{array}{ccc} * & \xrightarrow{g_\gamma^{A'}} & * \\ \uparrow 1_G & \begin{array}{c} \xrightarrow{f_\gamma^{(A, \eta)}} \\ \uparrow 1_G \end{array} & \doteq \\ * & \xrightarrow{g_\gamma^A} & * \end{array} \quad \begin{array}{ccc} * & \xrightarrow{g_\gamma^{A'}} & * \\ \uparrow 1_G & \begin{array}{c} \xrightarrow{e_{\gamma \times I}^{(A_\eta, B_\eta)}} \\ \uparrow 1_G \end{array} & \\ * & \xrightarrow{g_\gamma^A} & * \end{array}$$

Here $A_\eta = A + z\partial(\eta) \in \mathcal{A}^1(M \times I, \mathfrak{g})$ and

$$B_\eta = B + zd\eta + \frac{1}{2}z^2\eta \wedge^{\text{ad}} \eta + zA \wedge^\triangleright \eta + dz \wedge \eta \in \mathcal{A}^2(M \times I, \mathfrak{e}),$$

where $I = [0, 1]$, with coordinate z . It is an easy calculation to prove that $\partial(B_\eta) = \Omega_{A_\eta}$. In addition, $\gamma \times I: [0, 1]^2 \rightarrow M \times I$ is the map $(\gamma \times I)(t, s) = (\gamma(t), s)$, where $s, t \in [0, 1]$. We will see below (Remark 4.7) that $f_\gamma^{(A, \eta)} = e_{\gamma \times I}^{(A_\eta, B_\eta)}$ depends only on A, γ and η .

Let $h: M \rightarrow G$ be a smooth map. It is well known (and easy to prove) that if $A'' = h^{-1}A'h + h^{-1}dh$ then

$$\tau_{A'}^h(\gamma) = \begin{array}{ccc} & * \xrightarrow{g_\gamma^{A''}} * & \\ h(\gamma(0)) \uparrow & 1_E & \uparrow h(\gamma(1)) \\ & * \xrightarrow{g_\gamma^{A'}} * & \end{array}$$

is a 2-square in \mathcal{G} . This leads us to the following:

Definition 4.6 We say that (A'', B'') and (A, B) are related by the 1-gauge transformation (h, η) , when

$$A'' = h^{-1}(A + \partial(\eta))h + h^{-1}dh$$

and

$$B'' = h^{-1} \triangleright (B + d\eta + A \wedge^\triangleright \eta + \frac{1}{2} \eta \wedge^{\text{ad}} \eta).$$

We also define 2-squares relating the holonomies along γ with respect to A and A'' :

$$\tau_A^{(h, \eta)}(\gamma) \doteq \begin{array}{ccc} & * \xrightarrow{g_\gamma^{A''}} * & \\ \tau_{A'}^h(\gamma) & \begin{array}{c} \uparrow (A, \eta) \\ f_\gamma \end{array} & \uparrow h(\gamma(1)) \\ \tau_A^{(1_G, \eta)}(\gamma) & h(\gamma(0)) \uparrow & \\ & * \xrightarrow{g_\gamma^A} * & \end{array} \quad (4.1)$$

and

$$\hat{\tau}_A^{(h, \eta)}(\gamma) = r_{xy} \left(\tau_A^{(h, \eta)}(\gamma) \right) = \begin{array}{ccc} & * \xrightarrow{h(\gamma(1))} * & \\ g_\gamma^A \uparrow & \left(f_\gamma^{(A, \eta)} \right)^{-1} & \uparrow g_\gamma^{A''} \\ & * \xrightarrow{h(\gamma(0))} * & \end{array} \quad (4.2)$$

see 2.2.1.

Remark 4.7 By the Non-Abelian Fubini's Theorem, $e_{\gamma \times I}^{(A_\eta, B_\eta)} = e_{\gamma \times I}^{(A_\eta, B_\eta)}(1, 1)$, where $e_{\gamma \times I}^{(A_\eta, B_\eta)}(t, z)$ can be defined by either of the following differential equations:

$$\frac{\partial}{\partial z} e_{\gamma \times I}^{(A_\eta, B_\eta)}(t, z) = - e_{\gamma \times I}^{(A_\eta, B_\eta)}(t, z) \int_0^t A_z g_\gamma(t') \triangleright \eta \left(\frac{\partial}{\partial t'} \gamma(t') \right) dt',$$

where $A_z = A + z\partial(\eta) \in \mathcal{A}^1(M, \mathfrak{g})$, or

$$\frac{\partial}{\partial t} e_{\gamma \times I}^{(A_\eta, B_\eta)}(t, z) = \left(-z g_\gamma^A(t) \triangleright \eta \left(\frac{\partial}{\partial t} \gamma(t) \right) \right) e_{\gamma \times I}^{(A_\eta, B_\eta)}(t, z)$$

with initial conditions:

$$e_{\gamma \times I}^{(A_\eta, B_\eta)}(\xi, 0) = 1_E \text{ or } e_{\gamma \times I}^{(A_\eta, B_\eta)}(0, \xi) = 1_E, \text{ where } \xi \in [0, 1],$$

in the first and second case, respectively. Therefore it follows that $e_{\gamma \times I}^{(A_\eta, B_\eta)}$ depends only on A, η and γ , thus it can be written simply as $f_\gamma^{(A, \eta)}$.

There is another setting for the 2-cubes τ and $\hat{\tau}$ introduced here, which will be needed when we return to considering local connection pairs (A_i, B_i) (Definition 3.4), namely

$$\tau_{A_i}^{(\phi_{ij}, \eta_{ij})}(\gamma), \quad \hat{\tau}_{A_i}^{(\phi_{ij}, \eta_{ij})}(\gamma)$$

where γ is a 1-path whose image is contained in U_{ij} . We will refer to these 2-cubes as a transition 2-cubes for the 1-path γ . Note that the relation between A_i and A_j is identical to that between A and A'' , replacing h by ϕ_{ij} and η by η_{ij} .

4.2.1 The group of 1-gauge transformations

Let M be a smooth manifold. Let also $\mathcal{G} = (\partial: E \rightarrow G, \triangleright)$ be a Lie crossed module with associated differential crossed module $\mathfrak{G} = (\partial: \mathfrak{e} \rightarrow \mathfrak{g}, \triangleright)$. The group of 1-gauge transformations in M is the group of pairs (h, η) , where $h: M \rightarrow G$ is smooth, and η is an \mathfrak{e} -valued 1-form in M . The product law will be given by the semidirect product: $(h, \eta)(h', \eta') = (hh', h \triangleright \eta' + \eta)$. Recall that a local connection pair in M is given by a pair of forms $A \in \mathcal{A}^1(M, \mathfrak{g})$ and $B \in \mathcal{A}^2(M, \mathfrak{e})$ with $\partial(B) = \Omega_A = dA + \frac{1}{2}A \wedge^{\text{ad}} A$. Then defining:

$$(A, B) \triangleleft (h, \eta) = \left(h^{-1}Ah + \partial(h^{-1} \triangleright \eta) + h^{-1}dh, h^{-1} \triangleright (B + d\eta + A \wedge^{\triangleright} \eta + \frac{1}{2}\eta \wedge^{\text{ad}} \eta) \right)$$

which is equivalent to saying

$$(A'', B'') = (A, B) \triangleleft (h, \eta)$$

in terms of Definition 4.6, defines a right action of the group of 1-gauge transformations on the set of local connection pairs.

4.2.2 The coherence law for 1-gauge transformations

The following theorem expresses how the holonomy of a local connection pair changes under the group of 1-gauge transformations. We recall the notation of 2.1.1, 2.2.2 and 4.2.1. The notion of a flat \mathcal{G} -colouring appears in 2.2.2.

Theorem 4.8 (Coherence law for 1-gauge transformations) *Let M be a smooth manifold with a local connection pair (A, B) . Let also (h, η) be a 1-gauge transformation, and let $(A'', B'') = (A, B) \triangleleft (h, \eta)$. Let $\Gamma: [0, 1]^2 \rightarrow M$ be*

a smooth map. Define $T_{(A,B)}^{(h,\eta)}(\Gamma) = T_{(A,B)}^{(h,\eta)}$ as being the \mathcal{G} -colouring of the 3-cube D^3 such that:

$$T_{(A,B)}^{(h,\eta)} \circ \delta_3^- = \mathcal{H}^{(A,B)}(\Gamma), \quad T_{(A,B)}^{(h,\eta)} \circ \delta_3^+ = \mathcal{H}^{(A'',B'')}(\Gamma)$$

and

$$T_{(A,B)}^{(h,\eta)} \circ \delta_i^\pm = \tau_A^{(h,\eta)}(\partial_i^\pm \Gamma), \quad i = 1, 2.$$

(Note that the colourings of the edges of D^3 are determined from the colourings of the faces of it, given that they coincide in their intersections.) Then $T_{(A,B)}^{(h,\eta)}$ is flat.

Proof. The colouring $T_{(A',B')}^{(h,0)}(\Gamma)$ is flat by Lemma 2.28; here $(A', B') = (A, B) \triangleleft (1_G, \eta)$. Let us prove that the colouring $T_{(A,B)}^{(1_G, \eta)}(\Gamma)$ is flat. This follows from theorems 2.31 or 4.5 and the fact that if $\mathcal{M}_\eta = dB_\eta + A_\eta \wedge^\triangleright B_\eta \in \mathcal{A}^3(M \times \{z, z \in \mathbb{R}\}, \mathfrak{e})$ is the 2-curvature 3-form of (A_η, B_η) then the contraction of \mathcal{M}_η with the vector field $\frac{\partial}{\partial z}$ vanishes. A more intricate calculation of this type appears in the proof of Theorem 4.20. The theorem follows from the fact that $\mathcal{T}(\mathcal{G})$, the set of flat \mathcal{G} -colourings of the 3-cube D^3 , is a (strict) triple groupoid (see 2.2.2) and $T_{(A,B)}^{(h,\eta)} = T_{(A,B)}^{(1_G, \eta)} \circ_3 T_{(A',B')}^{(h,0)}$, where \circ_3 denotes upwards composition. ■

From remark 4.7 it follows:

Corollary 4.9 Suppose $\Gamma: [0, 1]^2 \rightarrow M$ is such that $\Gamma(\partial[0, 1]^2) = x$, where $x \in M$. Given a local connection pair (A, B) in M and a 1-gauge transformation (h, η) we then have:

$$e_\Gamma^{(A,B) \triangleleft (h,\eta)} = h^{-1}(x) \triangleright e_\Gamma^{(A,B)}.$$

By construction we have:

Corollary 4.10 Given a local connection pair (A, B) in M and a 1-gauge transformation $(h, 0)$ we then have for any smooth map $\Gamma: [0, 1]^2 \rightarrow M$:

$$e_\Gamma^{(A,B) \triangleleft (h,0)} = h^{-1}(\Gamma(0,0)) \triangleright e_\Gamma^{(A,B)}.$$

Theorem 4.8 may also be interpreted in a different way to give a relation between the holonomies for a 2-path Γ with image contained in U_{ij} , using local connection pairs (A_i, B_i) and (A_j, B_j) ; Definition 3.4. Note that $(A_j, B_j) = (A_i, B_i) \triangleleft (\phi_{ij}, \eta_{ij})$.

Theorem 4.11 (Transition 3-cube for a 2-path) Given a connection on a cubical \mathcal{G} -2-bundle over a pair (M, \mathcal{U}) , let $\Gamma: [0, 1]^2 \rightarrow M$ be a smooth 2-path with image contained in U_{ij} . Define $T_{(A_i, B_i)}^{(\phi_{ij}, \eta_{ij})}(\Gamma) = T_{(A_i, B_i)}^{(\phi_{ij}, \eta_{ij})}$ as being the \mathcal{G} -colouring of the 3-cube D^3 such that:

$$T_{(A_i, B_i)}^{(\phi_{ij}, \eta_{ij})} \circ \delta_3^- = \mathcal{H}^{(A_i, B_i)}(\Gamma), \quad T_{(A_i, B_i)}^{(\phi_{ij}, \eta_{ij})} \circ \delta_3^+ = \mathcal{H}^{(A_j, B_j)}(\Gamma)$$

and

$$T_{(A_i, B_i)}^{(\phi_{ij}, \eta_{ij})} \circ \delta_k^\pm = \tau_{A_i}^{(\phi_{ij}, \eta_{ij})}(\partial_i^\pm \Gamma), \quad k = 1, 2.$$

Then $T_{(A_i, B_i)}^{(\phi_{ij}, \eta_{ij})}$ is flat.

4.2.3 Dihedral symmetry for 1-gauge transformations

Let M be a manifold with a local connection pair (A, B) and a 1-gauge transformation (h, η) . Let $\gamma: [0, 1] \rightarrow M$ be a smooth map.

Theorem 4.12 *We have:*

1. $\tau_A^{(h, \eta)}(\gamma^{-1}) = \tau_A^{(h, \eta)}(\gamma)^{-h}$
2. If $(A'', B'') = (A, B) \triangleleft (h, \eta)$ then $\tau_{A''}^{(h, \eta)^{-1}}(\gamma) = \left(\tau_A^{(h, \eta)}(\gamma) \right)^{-v}$.

Recall $e^{-h} = r_x(e)$ and $e^{-v} = r_y(e)$, where $e \in \mathcal{D}^2(\mathcal{G})$, denote the horizontal and vertical inversions of squares in \mathcal{G} .

Proof. The first statement is immediate. Let $h_0 = h(\gamma(0))$, $h_1 = h(\gamma(1))$ and $\eta' = -h^{-1} \triangleright \eta$. Let also $(A', B') = (A, B) \triangleleft (0, \eta)$. The second statement follows from:

$$\begin{array}{ccc} & * \xrightarrow{g_\gamma^A} * & * \xrightarrow{g_\gamma^A} * \\ h_0^{-1} \uparrow & \begin{array}{c} (A'', \eta') \\ f_\gamma \end{array} \uparrow & h_0^{\triangleright} \uparrow & \begin{array}{c} (A'', \eta') \\ f_\gamma \end{array} \uparrow & 1_G \uparrow & \begin{array}{c} (A'', \eta') \\ f_\gamma \end{array} \uparrow & \uparrow 1_G \\ \tau_{A''}^{(h, \eta)^{-1}}(\gamma) & = & & = & & & \\ \tau_A^{(h, \eta)}(\gamma) & & & & & & \\ h_0 \uparrow & \begin{array}{c} (A, \eta) \\ f_\gamma \end{array} \uparrow & h_1 \uparrow & \begin{array}{c} (A, \eta) \\ f_\gamma \end{array} \uparrow & 1_G \uparrow & \begin{array}{c} (A, \eta) \\ f_\gamma \end{array} \uparrow & \uparrow 1_G \\ & * \xrightarrow{g_\gamma^A} * & * \xrightarrow{g_\gamma^A} * & & & & \end{array}$$

Now note

$$h_0 \triangleright \begin{array}{c} (A'', \eta') \\ f_\gamma \end{array} = \begin{array}{c} (A', -\eta) \\ f_\gamma \end{array} = \left(\begin{array}{c} (A, \eta) \\ f_\gamma \end{array} \right)^{-1};$$

the last equation can be inferred for example from the first equation of Remark 4.7. ■

4.3 Equivalence of cubical \mathcal{G} -2-bundles with connection

Let M be a smooth manifold. Let $\mathcal{G} = (\partial: E \rightarrow G, \triangleright)$ be a Lie crossed module and let $\mathfrak{G} = (\partial: \mathfrak{e} \rightarrow \mathfrak{g}, \triangleright)$ be the associated differential crossed module. We freely use the material of section 3.

4.3.1 A crossed module of groupoids of gauge transformations

We define a groupoid $M_{\mathcal{G}}^1$, whose set of objects $M_{\mathcal{G}}^0$ is given by the set of local connection pairs (A, B) in M , in other words $A \in \mathcal{A}^1(M, \mathfrak{g})$ and $B \in \mathcal{A}^2(M, \mathfrak{e})$ are smooth forms such that $\partial(B) = \Omega_A = dA + \frac{1}{2}A \wedge^{\text{ad}} A$. The set of morphisms of $M_{\mathcal{G}}^1$ is given by all quadruples of the form (A, B, ϕ, η) where A and B are as above, $\phi: M \rightarrow G$ is a smooth map and $\eta \in \mathcal{A}^1(M, \mathfrak{e})$ is an \mathfrak{e} -valued smooth 1-form in M . The source of (A, B, ϕ, η) is (A, B) and its target is $(A, B) \triangleleft (\phi, \eta)$. The composition is given by the product of 1-gauge transformations; see 4.2.1. We also define a totally intransitive groupoid $M_{\mathcal{G}}^2$, consisting of all triples of the form (A, B, ψ) , where (A, B) is a local connection pair in M and ψ is a smooth map $M \rightarrow E$. The source and target of (A, B, ψ) each are given by (A, B) , and we define $(A, B, \psi)(A, B, \psi') = (A, B, \psi\psi')$.

The following lemma states that this gives rise to a crossed module of groupoids, a notion defined in [BH1, BHS, B1], for example. We follow the conventions of [FMPO].

Lemma 4.13 *The map $\partial: M_{\mathcal{G}}^2 \rightarrow M_{\mathcal{G}}^1$ such that*

$$(A, B, \psi) \mapsto (A, B, \partial\psi, \psi(d\psi^{-1}) + \psi(A \triangleright \psi^{-1}))$$

is a groupoid morphism, and together with the left action:

$$(A, B, \phi, \eta) \triangleright (A', B', \psi) = (A, B, \phi \triangleright \psi),$$

where $(A', B') = (A, B) \triangleleft (\phi, \eta)$, of the groupoid $M_{\mathcal{G}}^1$ on the totally intransitive groupoid $M_{\mathcal{G}}^2$ defines a crossed module of groupoids $M_{\mathcal{G}}$.

Proof. Much of this is straightforward calculations. One complicated bit is to prove that:

$$(A, B) \triangleleft (\partial\psi, \psi(d\psi^{-1}) + \psi(A \triangleright \psi^{-1})) = (A, B) \quad (4.3)$$

It is easy to see that this is true at the level of 1-forms. At the level of the 2-forms we need to prove:

$$\begin{aligned} B &= (\partial\psi)^{-1} \triangleright \left(B + d(\psi(d\psi^{-1})) + d(\psi(A \triangleright \psi^{-1})) + A \wedge^{\triangleright} (\psi(d\psi^{-1})) + A \wedge^{\triangleright} (\psi(A \triangleright \psi^{-1})) \right. \\ &\quad \left. + \frac{(\psi(d\psi^{-1}) \wedge^{\text{ad}} (\psi(d\psi^{-1})))}{2} + \frac{(\psi(A \triangleright \psi^{-1}) \wedge^{\text{ad}} (\psi(A \triangleright \psi^{-1})))}{2} \right. \\ &\quad \left. + (\psi(d\psi^{-1}) \wedge^{\text{ad}} (\psi(A \triangleright \psi^{-1}))) \right). \quad (4.4) \end{aligned}$$

We can eliminate two terms by using:

$$d(\psi(d\psi^{-1})) + \frac{(\psi(d\psi^{-1}) \wedge^{\text{ad}} (\psi(d\psi^{-1})))}{2} = 0,$$

which follows from the fact $d\theta = \frac{1}{2}\theta \wedge^{\text{ad}} \theta$, where θ is the Maurer-Cartan form. By using the Leibnitz rule it follows that:

$$A \wedge^{\triangleright} (\psi(A \triangleright \psi^{-1})) + \frac{(\psi(A \triangleright \psi^{-1}) \wedge^{\text{ad}} (\psi(A \triangleright \psi^{-1})))}{2} = \psi \left(\left(\frac{A \wedge^{\text{ad}} A}{2} \right) \triangleright \psi^{-1} \right).$$

Also we have

$$d(\psi(A \triangleright \psi^{-1})) + A \wedge^\triangleright (\psi d\psi^{-1}) + \psi(d\psi^{-1}) \wedge^{\text{ad}} (\psi(A \triangleright \psi^{-1})) = \psi(dA \triangleright \psi^{-1}),$$

using $\psi(A \triangleright \psi^{-1}) = -(A \triangleright \psi)\psi^{-1}$ and $(d\psi)\psi^{-1} = -\psi d\psi^{-1}$.

Putting everything together, formula (4.4) reduces to:

$$\begin{aligned} \phi^{-1} \triangleright \left(B + \psi \left(\left(\frac{A \wedge^{\text{ad}} A}{2} \right) \triangleright \psi^{-1} \right) + \psi(dA \triangleright \psi^{-1}) \right) \\ = \phi^{-1} \triangleright (B + \psi(\partial(B)) \triangleright \psi^{-1}) \\ = \phi^{-1} \triangleright (B + \psi B \psi^{-1} - B) \\ = B. \end{aligned}$$

We have used the identity $\partial(V) \triangleright e = Ve - eV$ for each $V \in \mathfrak{e}$ and for each $e \in E$. This follows from the definition of a Lie crossed module.

We now prove the other difficult condition, namely:

$$\partial((A, B, \phi, \eta) \triangleright (A', B', \psi)) = (A, B, \phi, \eta) \partial((A', B', \psi)(A', B', \phi^{-1}, -\phi^{-1} \triangleright \eta))$$

or

$$\begin{aligned} (A, B, \partial(\phi \triangleright \psi), (\phi \triangleright \psi)d(\phi \triangleright \psi)^{-1} + (\phi \triangleright \psi)A \triangleright (\phi \triangleright \psi^{-1})) \\ = (A, B, \phi\psi\phi^{-1}, \eta + (\phi \triangleright \psi)(\phi \triangleright d\psi^{-1}) + (\phi \triangleright \psi)(\phi A' \triangleright \psi^{-1}) - \phi\partial(\psi)\phi^{-1} \triangleright \eta) \end{aligned} \quad (4.5)$$

Now use the fact that $A' = \phi^{-1}A\phi + \phi^{-1}d\phi + \partial(\phi^{-1} \triangleright \eta)$, and the terms involving η on the right hand side cancel. ■

Definition 4.14 *The crossed module of groupoids $M_{\mathcal{G}}$ of the previous lemma will be called the crossed module of gauge transformations in M .*

A very similar construction appears in [SW2]. Note that the collection of crossed modules $U_{\mathcal{G}}$, one for each open set $U \subset M$, can naturally be assembled into a crossed module sheaf $\overline{M}_{\mathcal{G}}$ over M .

4.3.2 Equivalence of cubical \mathcal{G} -2-bundles with connection over a pair (M, \mathcal{U})

Definition 4.15 *We continue to fix a smooth manifold M . Given a point $x \in M$, the crossed module $M_{\mathcal{G}}(x)$ of germs of gauge transformations is constructed in the following obvious way from the crossed module sheaf $\overline{M}_{\mathcal{G}}$ over M . The set of objects $M_{\mathcal{G}}^0(x)$ of $M_{\mathcal{G}}(x)$ is given by the set of all triples (A, B, U) , with $(A, B) \in U_{\mathcal{G}}^0$, where U is open and $x \in U$, with the equivalence relation $(A, B, U) \cong (A', B', U')$ if $A = A'$ and $B = B'$ in some open neighbourhood of x . One proceeds analogously to define the morphisms $M_{\mathcal{G}}^1(x)$ and the 2-morphisms $M_{\mathcal{G}}^2(x)$ of $M_{\mathcal{G}}(x)$.*

Note that the evaluation at $x \in M$ gives maps

$$\begin{aligned} M_{\mathcal{G}}^0(x) &\rightarrow \text{Hom}(T_x(M), \mathfrak{g}) \times \text{Hom}(\wedge^2(T_x), \mathfrak{e}), \\ M_{\mathcal{G}}^1(x) &\rightarrow G \times \text{Hom}(T_x(M), \mathfrak{e}) \text{ and } M_{\mathcal{G}}^2(x) \rightarrow E. \end{aligned}$$

Therefore the set $\mathcal{N}(M_{\mathcal{G}}(x))^n$ of n -cubes of the cubical nerve $\mathcal{N}(M_{\mathcal{G}}(x))$ of $M_{\mathcal{G}}(x)$ (see [BHS, BHS] and 2.2.2), comes with a naturally defined map

$$\begin{aligned} t_x: \mathcal{N}(M_{\mathcal{G}}(x))^n &\rightarrow (\text{Hom}(T_x(M), \mathfrak{g}) \times \text{Hom}(\wedge^2(T_x), \mathfrak{e}))^{a_n} \\ &\quad \times (G \times \text{Hom}(T_x(M), \mathfrak{e}))^{b_n} \times E^{c_n}, \end{aligned}$$

where a_n, b_n and c_n denote the number of vertices, edges and two dimensional faces of the n -cube $[0, 1]^n$.

Consider the bundle $\cup_{x \in M} \mathcal{N}(M_{\mathcal{G}}(x))$, of cubical sets, which is itself a cubical set, where the set of n -cubes is given by $\cup_{x \in M} \mathcal{N}(M_{\mathcal{G}}(x))^n$, with the obvious faces and degeneracies. The set of n -cubes of $\cup_{x \in M} \mathcal{N}(M_{\mathcal{G}}(x))$ can be turned into a smooth space [BHo, Ch] by saying that a map $f: V \rightarrow \cup_{x \in M} \mathcal{N}(M_{\mathcal{G}}(x))^n$ is smooth if $(\cup_{x \in M} t_x) \circ f$ is smooth, where V is some open set in some \mathbb{R}^i . This upgrades the cubical set $\cup_{x \in M} \mathcal{N}(M_{\mathcal{G}}(x))$ to a cubical object in the category of smooth spaces, a cubical smooth space.

Theorem 4.16 *Let \mathcal{U} be an open cover of M . A cubical \mathcal{G} -2-bundle with connection over (M, \mathcal{U}) is given by a cubical map $C(M, \mathcal{U}, x) \xrightarrow{f_x} \mathcal{N}(M_{\mathcal{G}}(x))$, the cubical nerve of the crossed module of groupoids $M_{\mathcal{G}}(x)$, for each $x \in M$. This is to verify the following smoothness condition: The collection*

$$\bigcup_{x \in M} f_x: C(M, \mathcal{U}, x) \rightarrow \bigcup_{x \in M} \mathcal{N}(M_{\mathcal{G}}(x))$$

is a map of cubical smooth spaces (recall that $C(M, \mathcal{U})$ is a cubical manifold).

Proof. Easy calculations. ■

Definition 4.17 *We say that two cubical \mathcal{G} -2-bundles with connection \mathcal{B} and \mathcal{B}' over a pair (M, \mathcal{U}) , say $(\phi_{ij}, \psi_{ijkl}, A_i, B_i, \eta_{ij})$ and $(\phi'_{ij}, \psi'_{ijkl}, A'_i, B'_i, \eta'_{ij})$, are equivalent (and we write $\mathcal{B} \cong_{\mathcal{U}} \mathcal{B}'$) if the associated cubical maps $C(M, \mathcal{U}, x) \rightarrow \mathcal{N}(M_{\mathcal{G}}(x))$, where $x \in M$, are homotopic, through a smooth homotopy (in the sense above).*

The fact that the cubical nerve of a crossed module of groupoids is a Kan cubical set [BH5, BHS] can be used to prove that this is an equivalence relation.

Explicitly, $\mathcal{B} \cong_{\mathcal{U}} \mathcal{B}'$ if there exist smooth maps $\Phi_i: U_i \rightarrow G$ and $\Psi_{ij}: U_{ij} \rightarrow E$, as well as smooth forms $\mathcal{E}_i \in \mathcal{A}^1(U_i, \mathfrak{e})$ such that:

1. We have

$$\partial(A_i, B_i, \Psi_{ij}^{-1})(A_i, B_i, \Phi_i, \mathcal{E}_i)(A'_i, B'_i, \phi'_{ij}, \eta'_{ij}) = (A_i, B_i, \phi_{ij}, \eta_{ij})(A_j, B_j, \Phi_j, \mathcal{E}_j),$$

where we suppose $(A'_i, B'_i) = (A_i, B_i) \triangleleft (\Phi_i, \mathcal{E}_i)$ and $(A_j, B_j) = (A_i, B_i) \triangleleft (\phi_{ij}, \eta_{ij})$.

2. The colouring T of D^3 such that $\partial_3^-(T) = (\phi, \psi)_{ijkl}$, $\partial_3^+(T) = (\phi', \psi')_{ijkl}$ (see subsection 4.4), and

$$\begin{array}{ccc}
& * \xrightarrow{\phi'_{ij}} * & * \xrightarrow{\phi'_{kl}} * \\
T_1^- = \Phi_i \uparrow & \Psi_{ij} \uparrow \Phi_j, & T_1^+ = \Phi_k \uparrow \Psi_{kl} \uparrow \Phi_l \\
& * \xrightarrow{\phi_{ij}} * & * \xrightarrow{\phi_{kl}} * \\
\\
& * \xrightarrow{\phi'_{ik}} * & * \xrightarrow{\phi'_{jl}} * \\
T_2^- = \Phi_i \uparrow & \Psi_{ik} \uparrow \Phi_k, & T_2^+ = \Phi_j \uparrow \Psi_{jl} \uparrow \Phi_l \\
& * \xrightarrow{\phi_{ik}} * & * \xrightarrow{\phi_{jl}} *
\end{array}$$

is flat for each $x \in U_{ij}$ and any i, j ; see 2.2.2. We have put $T_i^\pm = T \circ \delta_i^\pm = \partial_i^\pm(T)$.

We can easily see that this defines an equivalence relation on the set of cubical \mathcal{G} -2-bundles over (M, \mathcal{U}) .

4.3.3 Subdivisions of covers and the equivalence of cubical \mathcal{G} -2-bundles over a manifold

Let $\mathcal{U} = \{U_i\}_{i \in \mathcal{J}}$ be an open cover of M . A subdivision \mathcal{V} of \mathcal{U} is a map $i \in \mathcal{J} \mapsto S_i$, where S_i is a set, together with open sets $V_a \subset U_i$, for each $a \in S_i$ such that $U_i = \cup_{a \in S_i} V_a$. If we are given a cubical \mathcal{G} -2-bundle with connection \mathcal{B} over $C(M, \mathcal{U})$, we immediately have another one, $\mathcal{B}_\mathcal{V}$ over $\mathcal{V} = \{V_a\}_{a \in S_i, i \in \mathcal{J}}$, provided by the obvious cubical map $C(M, \mathcal{V}) \rightarrow C(M, \mathcal{U})$. Its structure maps are such that e.g. $\phi_{ab} = \phi_{ij}|_{V_a \cap V_b}$, where $a \in S_i$ and $b \in S_j$, and analogously for all the remaining information needed to specify a cubical \mathcal{G} -2-bundle with connection. For the same reason, it is easy to see that if $\mathcal{B} \cong_{\mathcal{U}} \mathcal{B}'$ then $\mathcal{B}_\mathcal{V} \cong_{\mathcal{V}} \mathcal{B}'_\mathcal{V}$ for any subdivision \mathcal{V} of \mathcal{U} .

If $\mathcal{U} = \{U_i\}_{i \in \mathcal{J}}$ and $\mathcal{W} = \{W_j\}_{j \in \mathcal{J}}$ are open covers of M , then $\mathcal{U} \cap \mathcal{W}$ is the open cover $\{U_i \cap W_j\}_{(i,j) \in \mathcal{J} \times \mathcal{J}}$. It is a subdivision of both \mathcal{U} and \mathcal{W} in the obvious way.

Definition 4.18 (Equivalence of cubical \mathcal{G} -2-bundles with connection)

Two cubical \mathcal{G} -2-bundles with connection \mathcal{B} and \mathcal{B}' over the open covers $\mathcal{U} = \{U_i\}_{i \in \mathcal{J}}$ and $\mathcal{W} = \{W_j\}_{j \in \mathcal{J}}$ of M , respectively, are called equivalent if

$$\mathcal{B}_{\mathcal{U} \cap \mathcal{W}} \cong_{\mathcal{U} \cap \mathcal{W}} \mathcal{B}'_{\mathcal{U} \cap \mathcal{W}}$$

The following follows from the previous discussion.

Theorem 4.19 *Equivalence of cubical \mathcal{G} -2-bundles with connection is an equivalence relation.*

4.4 Coherence law for transition 2-cubes

Let \mathcal{B} be a cubical \mathcal{G} -2-bundle with connection over (M, \mathcal{U}) (Definition 3.4). Suppose γ is a 1-path whose image is contained in the overlap U_{ijkl} . Recall the notation in 2.2.1, 2.2.2 and subsection 4.2, in particular the notion of transition 2-cube for the path γ . Recall from Definition 3.1 the 2-cube (for each $x \in M$):

$$(\psi, \phi)_{ijkl} = \begin{array}{ccc} & * \xrightarrow{\phi_{kl}} * & \\ \phi_{ik} \uparrow & \psi_{ijkl} & \uparrow \phi_{jl} \\ & * \xrightarrow{\phi_{ij}} * & \end{array} \quad (4.6)$$

Theorem 4.20 (Coherence law for transition 2-cubes) *Let $\gamma: [0, 1] \rightarrow U_{ijkl} \subset M$ be a smooth map. We have:*

$$\begin{aligned} \hat{\tau}_{A_i}^{(\phi_{ik}, \eta_{ik})}(\gamma) \hat{\tau}_{A_k}^{(\phi_{kl}, \eta_{kl})}(\gamma) \left(\hat{\tau}_{A_j}^{(\phi_{jl}, \eta_{jl})} \right)^{-h}(\gamma) \left(\hat{\tau}_{A_i}^{(\phi_{ij}, \eta_{ij})} \right)^{-h}(\gamma) \\ \Phi((\psi, \phi)_{ijkl}(\gamma(0))) \\ = \Phi'_{g_\gamma}^{A_i}((\psi, \phi)_{ijkl}(\gamma(1))), \end{aligned} \quad (4.7)$$

and therefore the \mathcal{G} -colouring T of D^3 such that:

$$T \circ \delta_2^- = (\psi, \phi)_{ijkl}(\gamma(0)), \quad T \circ \delta_2^+ = (\psi, \phi)_{ijkl}(\gamma(1))$$

and

$$\begin{aligned} T \circ \delta_1^- &= \tau_{A_i}^{(\phi_{ik}, \eta_{ik})}(\gamma), & T \circ \delta_3^+ &= \hat{\tau}_{A_k}^{(\phi_{kl}, \eta_{kl})}(\gamma), \\ T \circ \delta_1^+ &= \tau_{A_j}^{(\phi_{jl}, \eta_{jl})}(\gamma), & T \circ \delta_3^- &= \hat{\tau}_{A_i}^{(\phi_{ij}, \eta_{ij})}(\gamma), \end{aligned}$$

is flat.

Proof. By Theorem 4.12, the left hand side $F(\gamma)$ of (4.7) is (we omit the γ):

$$\begin{aligned} \hat{\tau}_{A_i}^{(\phi_{ik}, \eta_{ik})} \hat{\tau}_{A_k}^{(\phi_{kl}, \eta_{kl})} \hat{\tau}_{A_l}^{(\phi_{jl}, \eta_{jl})}^{-1} \hat{\tau}_{A_j}^{(\phi_{ij}, \eta_{ij})}^{-1} \\ \Phi((\psi, \phi)_{ijkl}(\gamma(0))) \end{aligned}$$

which can also be written as:

$$\begin{aligned} \left[\begin{array}{cccc} \hat{\tau}_{A_i}^{(1, \eta_{ik})} & \hat{\tau}_{\phi_{ik} \triangleright A_k}^{(1, \phi_{ik} \triangleright \eta_{kl})} & \hat{\tau}_{\phi_{ik} \phi_{kl} \phi_{jl}^{-1} \triangleright A_l}^{(1, -\phi_{ik} \phi_{kl} \phi_{jl}^{-1} \triangleright \eta_{jl})} & \hat{\tau}_{\phi_{ik} \phi_{kl} \phi_{jl}^{-1} \phi_{ij}^{-1} \triangleright A_j}^{(1, -\phi_{ik} \phi_{kl} \phi_{jl}^{-1} \phi_{ij}^{-1} \triangleright \eta_{ij})} \end{array} \right] \circ_h \\ \text{id} \\ \left[\begin{array}{cccc} \hat{\tau}_{\phi_{ik} \phi_{kl} \phi_{jl}^{-1} \phi_{ij}^{-1} \triangleright A_i}^{\phi_{ik}} & \hat{\tau}_{\phi_{kl} \phi_{jl}^{-1} \phi_{ij}^{-1} \triangleright A_k}^{\phi_{kl}} & \hat{\tau}_{\phi_{jl}^{-1} \phi_{ij}^{-1} \triangleright A_l}^{\phi_{jl}^{-1}} & \hat{\tau}_{\phi_{ij}^{-1} \triangleright A_j}^{\phi_{ij}^{-1}} \end{array} \right] \\ \Phi((\psi, \phi)_{ijkl}(\gamma(0))) \end{aligned}$$

Here we have put $\phi \triangleright A = A \triangleleft \phi^{-1} = \phi A \phi^{-1} + \phi d\phi^{-1}$. Let $\gamma_t: [0, 1] \rightarrow M$ be the path $\gamma_t(t') = \gamma(t't)$, where $t, t' \in [0, 1]$. Let also $F'(\gamma_t) \in E$ be the element assigned to the square $F(\gamma_t)$. We then have (by using Remark 4.7):

$$\begin{aligned} \frac{d}{dt} F'(\gamma_t) &= F'(\gamma_t) \overset{A_i}{g}_{\gamma_t} \triangleright \left(\eta_{ik} + \phi_{ik} \triangleright \eta_{kl} - \phi_{ik} \phi_{kl} \phi_{jl}^{-1} \triangleright \eta_{jl} - \phi_{ik} \phi_{kl} \phi_{jl}^{-1} \phi_{ij}^{-1} \triangleright \eta_{ij} \right) \frac{d}{dt} \gamma(t) \\ &= F'(\gamma_t) \overset{A_i}{g}_{\gamma_t} \triangleright \left(\psi_{ijkl}^{-1} d\psi_{ijkl} + \psi_{ijkl}^{-1} (A_i \triangleright \psi_{ijkl}) \right) \frac{d}{dt} \gamma(t) \end{aligned}$$

On the other hand:

$$\begin{aligned} \frac{d}{dt} \left(\overset{A_i}{g}_{\gamma_t} \triangleright \psi_{ijkl}(\gamma(t)) \right) &= \left(\overset{A_i}{g}_{\gamma_t} A_i \triangleright \psi_{ijkl} + \overset{A_i}{g}_{\gamma_t} \triangleright d\psi_{ijkl} \right) \frac{d}{dt} \gamma(t) \\ &= \left(\overset{A_i}{g}_{\gamma_t} \triangleright \psi_{ijkl} \right) \left(\overset{A_i}{g}_{\gamma_t} \triangleright \psi_{ijkl}^{-1} \right) \left(\overset{A_i}{g}_{\gamma_t} A_i \triangleright \psi_{ijkl} + \overset{A_i}{g}_{\gamma_t} \triangleright d\psi_{ijkl} \right) \frac{d}{dt} \gamma(t) \\ &= \left(\overset{A_i}{g}_{\gamma_t} \triangleright \psi_{ijkl} \right) \overset{A_i}{g}_{\gamma_t} \triangleright \left(\psi_{ijkl}^{-1} d\psi_{ijkl} + \psi_{ijkl}^{-1} (A_i \triangleright \psi_{ijkl}) \right) \frac{d}{dt} \gamma(t). \end{aligned}$$

This proves that $F'(\gamma_t) = \overset{A_i}{g}_{\gamma_t} \triangleright \psi_{ijkl}(\gamma(t))$, which by taking $t = 1$ finishes the proof. ■

5 Wilson spheres and tori

5.1 Holonomy for an arbitrary 2-path in a smooth manifold

We recall the notation of subsections 4.1, 4.2 and 4.4.

5.1.1 Patching together local holonomies and transition functions

Let M be a smooth manifold. Let also $\mathcal{G} = (\partial: E \rightarrow G, \triangleright)$ be a Lie crossed module with associated differential crossed module $\mathfrak{G} = (\partial: \mathfrak{e} \rightarrow \mathfrak{g}, \triangleright)$. Let $\mathcal{U} = \{U_i\}_{i \in \mathcal{J}}$ be an open cover of M . Let \mathcal{B} be a cubical \mathcal{G} -2-bundle over (M, \mathcal{U}) with connection, given by $\{\phi_{ij}, \psi_{ijkl}\}_{i,j,k,l \in \mathcal{J}}$ (Definition 3.1) and $\{A_i, B_i, \eta_{ij}\}_{i,j \in \mathcal{J}}$ (Definition 3.4).

Let $\Gamma: [0, 1]^2 \rightarrow M$ be a 2-path. Let \mathcal{Q} denote a subdivision of $[0, 1]^2$ into rectangles $\{Q_R\}_{R \in \mathcal{R}}$, where \mathcal{R} is some index set, by means of partitions of each $[0, 1]$ factor, together with an assignment, to each $R \in \mathcal{R}$, of $i_R \in \mathcal{J}$, such that $\Gamma(Q_R) \subset U_{i_R}$. Such subdivisions with open set assignments (partitions \mathcal{Q} of Γ) do exist because of the Lebesgue Covering Lemma.

For each $R \in \mathcal{R}$, let $\Gamma_R: [0, 1]^2 \rightarrow M$ denote the restriction of Γ to Q_R , rescaled and reparametrized to be a 2-path $[0, 1]^2 \rightarrow M$. We reparametrize again to introduce additional 2-paths, which are thickened 1-paths, constant horizontally (e.g. $\hat{\gamma}_{ij}$ in Figure 2 or constant vertically (e.g. γ_{ik} in Figure 2), or thickened points, constant both horizontally and vertically (p_{ijkl} in Figure 2).

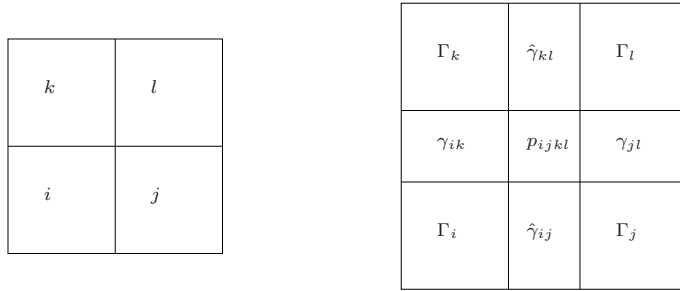

Figure 2: Decomposition of Γ for the definition of the holonomy of (Γ, \mathcal{Q})

To each 2-path in this array we assign a 2-cube of the double groupoid $\mathcal{D}^2(\mathcal{G})$, see 2.2.1, as follows:

$$\begin{aligned} \Gamma_i &\mapsto \mathcal{H}(\Gamma_i) \doteq \mathcal{H}^{(A_i, B_i)}(\Gamma_i) \\ \hat{\gamma}_{ij} &\mapsto \hat{\tau}(\hat{\gamma}_{ij}) \doteq \hat{\tau}_{A_i}^{(\phi_{ij}, \eta_{ij})}(\Gamma_i|_{\{1\} \times [0,1]}) \quad \text{or} \quad \gamma_{ik} \mapsto \tau(\gamma_{ik}) \doteq \tau_{A_i}^{(\phi_{ik}, \eta_{ik})}(\Gamma_i|_{[0,1] \times \{1\}}) \\ p_{ijkl} &\mapsto \psi(x)_{ijkl} \doteq (\psi, \phi)_{ijkl}(x) \end{aligned}$$

where $x \in M$ is the image of the constant 2-path p_{ijkl} . See Theorem 4.2 and equations (4.1), (4.2) and (4.6) for the definitions.

Definition 5.1 *Given a 2-path $\Gamma: [0,1]^2 \rightarrow M$ and a partition \mathcal{Q} of Γ , the holonomy of (Γ, \mathcal{Q}) for the cubical \mathcal{G} -2-bundle with connection \mathcal{B} , written*

$$\overset{\mathcal{B}}{\mathcal{H}}(\Gamma, \mathcal{Q}),$$

or simply $\mathcal{H}(\Gamma, \mathcal{Q})$ if the cubical \mathcal{G} -2-bundle with connection is clear from the context, is the composition of the 2-cubes of $\mathcal{D}^2(\mathcal{G})$ obtained from the above assignments. This is well defined due to the associativity and interchange law for the composition of squares in \mathcal{G} , which make up a double groupoid; see 2.2.1.

In the remainder of this chapter we will see that the 2-dimensional holonomy of Definition 5.1 does not depend (up to rather simple transformations) on the chosen partition of Γ , the chosen coordinate neighbourhoods, the choice of cubical \mathcal{G} -2-bundle with connection within the same equivalence class, or the choice of Γ within the same thin homotopy equivalence class. Furthermore, in the final section we will see how it can be associated to oriented embedded 2-spheres in a manifold, therefore defining Wilson 2-Sphere observables.

5.1.2 Independence under subdividing partitions

Proposition 5.2 *Suppose we introduce an extra point in one of the partitions underlying \mathcal{Q} , so as to subdivide one of the rows or columns of the partition of $[0,1]^2$. For this new subdivision, suppose we assign each of its rectangles to the*

same open set as that assigned by \mathcal{Q} to the rectangle in which it is contained, and call this new subdivision and assignment \mathcal{Q}' . Then

$$\mathcal{H}(\Gamma, \mathcal{Q}') = \mathcal{H}(\Gamma, \mathcal{Q})$$

Proof. (For the case of subdividing a row). The only change in the holonomy for \mathcal{Q}' is in the contributions along the subdivided row, where the open set assignments look like Figure 2 with $i = k$ and $j = l$. Since $\tau(\gamma_{ii})$ and $\psi_{ijij}(p)$ are thin elements of $\mathcal{D}^2(\mathcal{G})$ (from Definition 3.4 and Section 4.2, and from Definition 3.1 respectively), the composition of the three rows of rectangles after subdividing equals the composition of the original row of rectangles before subdividing. ■

5.1.3 The case of paths

Let $\gamma : [0, 1] \rightarrow M$ be a path. Let \mathcal{Q} denote a subdivision of $[0, 1]$ into subintervals $\{q_r\}_{r=1, \dots, s}$, together with an assignment, for each r , of $i_r \in \mathcal{I}$, such that $\gamma(q_r) \subset U_{i_r}$. For each r , let $\gamma_r : [0, 1] \rightarrow M$ denote the restriction of γ to q_r , rescaled and reparametrized to be a 1-path $[0, 1] \rightarrow M$. As for the case of 2-paths, we reparametrize again to introduce constant 1-paths $p_{r,r+1}$ with image $x_r = \gamma_r(1) = \gamma_{r+1}(0)$ between γ_r and γ_{r+1} . To each of these 1-paths we assign an element of G as follows:

$$\begin{aligned} \gamma_r &\mapsto g_{\gamma_r}^{A_{i_r}} \\ p_{r,r+1} &\mapsto \phi_{i_r i_{r+1}}(x_r) \end{aligned}$$

Definition 5.3 *The holonomy of (γ, \mathcal{Q}) for the cubical \mathcal{G} -2-bundle with connection \mathcal{B} , written*

$$\overset{\mathcal{B}}{\mathcal{H}}(\gamma, \mathcal{Q}),$$

or simply $\mathcal{H}(\gamma, \mathcal{Q})$ if the cubical \mathcal{G} -2-bundle with connection is clear from the context, is the composition of the 1-cubes of $\mathcal{D}^1(\mathcal{G})$ obtained from the above assignments. Concretely, we have the formula:

$$\overset{\mathcal{B}}{\mathcal{H}}(\gamma, \mathcal{Q}) = g_{\gamma_1}^{A_{i_1}} \phi_{i_1 i_2}(x_1) g_{\gamma_2}^{A_{i_2}} \phi_{i_2 i_3}(x_2) \cdots g_{\gamma_s}^{A_{i_s}}.$$

Let γ be a 1-path, and let $\mathcal{Q}, \mathcal{Q}'$ be based on the same subdivision of $[0, 1]$ into subintervals $\{q_r\}_{r=1, \dots, s}$, but with different assignments i_r and i'_r to each q_r . As in Definition 5.1, we replace γ by a product of 2-paths which are constant vertically, corresponding to γ_r , or constant horizontally and vertically, corresponding to x_r . We introduce the notation:

$$\overset{\mathcal{B}}{\mathcal{T}}(\gamma, \mathcal{Q}, \mathcal{Q}') \doteq \tau((\gamma_1)_{i_1 i'_1}) \psi(x_1)_{i_1 i_2 i'_1 i'_2} \tau((\gamma_2)_{i_2 i'_2}) \cdots \tau((\gamma_s)_{i_s i'_s}). \quad (5.1)$$

When \mathcal{B} is understood we will drop it from the notation. In particular, this denotes the evaluation of a row of the holonomy formula of Definition 5.1, with

γ being the restriction of Γ to one of the horizontal lines in the partition of $[0, 1]^2$. We have:

$$\partial_d \tau(\gamma, \mathcal{Q}, \mathcal{Q}') = \mathcal{H}(\gamma, \mathcal{Q}) \text{ and } \partial_u \tau(\gamma, \mathcal{Q}, \mathcal{Q}') = \mathcal{H}(\gamma, \mathcal{Q}'),$$

with \mathcal{B} understood everywhere.

5.1.4 The dependence of the holonomy on the partition \mathcal{Q}

We want to study the effect on the holonomy of substituting the subdivision with open set assignments \mathcal{Q} by \mathcal{Q}' . Since by the previous proposition, the holonomy is unaffected by subdividing the partition of $[0, 1]^2$, we can assume that the underlying subdivision of $[0, 1]^2$ is the same for \mathcal{Q} and \mathcal{Q}' , thus that \mathcal{Q} and \mathcal{Q}' differ only with respect to the open set assignments.

Theorem 5.4 (Coherence law for 2-holonomy) *Let $\Gamma: [0, 1]^2 \rightarrow M$ be a smooth map. Suppose \mathcal{Q} and \mathcal{Q}' are given by the same subdivision of $[0, 1]^2$ into rectangles $\{Q_R\}_{R \in \mathcal{R}}$, and assignments i_R and i'_R respectively to each rectangle Q_R such that $\Gamma(Q_R) \subset U_{i_R} \cap U_{i'_R}$. Then the respective holonomies of Γ are related by the homotopy addition equation (2.4) for $T \in D^3$, where T is given by:*

$$T \circ \delta_3^- = \mathcal{H}(\Gamma, \mathcal{Q}) \text{ and } T \circ \delta_3^+ = \mathcal{H}(\Gamma, \mathcal{Q}')$$

and

$$T \circ \delta_i^\pm = \tau(\partial_i^\pm(\Gamma), \partial_i^\pm \mathcal{Q}, \partial_i^\pm \mathcal{Q}'), \quad i = 1, 2;$$

where $\partial_i^\pm \mathcal{Q}$ and $\partial_i^\pm \mathcal{Q}'$ are the restrictions of \mathcal{Q} and \mathcal{Q}' to the corresponding faces. In other words the colouring T of D^3 is flat.

Proof. Analogously to the procedure in Definition 5.1, but now in three dimensions, we take the 3-path $\Gamma \times \text{id}_{[0,1]}$, with its domain $[0, 1]^3$ partitioned into rectangular solids by the partition of the domain of Γ underlying \mathcal{Q} and \mathcal{Q}' . We then reparametrize to replace the vertical surfaces and lines of the partition by 3-paths that are constant horizontally or vertically, or both horizontally and vertically. The flat cube $T \in \mathcal{T}^3(\mathcal{G})$ is the composition of elementary flat cubes of the following types.

To each 2-path Γ_R , we assign (see Theorem 4.11)

$$T(\Gamma_R, \mathcal{Q}, \mathcal{Q}') = T_{(A_{i_R}, B_{i_R})}^{(\phi_{i_R i'_R}, \eta_{i_R i'_R})}$$

To each $\hat{\gamma}_{RS} = \partial_1^+ \Gamma_R = \partial_1^- \Gamma_S$ we assign a version of the flat cube of Theorem 4.20, namely $T(\hat{\gamma}_{RS}, \mathcal{Q}, \mathcal{Q}')$ given by

$$\begin{cases} \partial_3^- T(\hat{\gamma}_{RS}, \mathcal{Q}, \mathcal{Q}') = \hat{\tau}(\gamma_{i_R i_S}), & \partial_3^+ T(\hat{\gamma}_{RS}, \mathcal{Q}, \mathcal{Q}') = \hat{\tau}(\gamma_{i'_R i'_S}) \\ \partial_1^- T(\hat{\gamma}_{RS}, \mathcal{Q}, \mathcal{Q}') = \tau(\gamma_{i_R i'_R}), & \partial_1^+ T(\hat{\gamma}_{RS}, \mathcal{Q}, \mathcal{Q}') = \tau(\gamma_{i_S i'_S}) \\ \partial_2^- T(\hat{\gamma}_{RS}, \mathcal{Q}, \mathcal{Q}') = \psi(\gamma(0)_{i_R i_S i'_R i'_S}), & \partial_2^+ T(\hat{\gamma}_{RS}, \mathcal{Q}, \mathcal{Q}') = \psi(\gamma(1)_{i_R i_S i'_R i'_S}) \end{cases}$$

To each $\gamma_{RS} = \partial_2^+ \Gamma_R = \partial_2^- \Gamma_S$ we assign a version of the flat cube of Theorem 4.20, namely $T(\gamma_{RS}, \mathcal{Q}, \mathcal{Q}')$ given by

$$\begin{cases} \partial_3^- T(\gamma_{RS}, \mathcal{Q}, \mathcal{Q}') = \tau(\gamma_{i_R i_S}), & \partial_3^+ T(\gamma_{RS}, \mathcal{Q}, \mathcal{Q}') = \tau(\gamma_{i'_R i'_S}) \\ \partial_2^- T(\gamma_{RS}, \mathcal{Q}, \mathcal{Q}') = \tau(\gamma_{i_R i'_R}), & \partial_2^+ T(\gamma_{RS}, \mathcal{Q}, \mathcal{Q}') = \tau(\gamma_{i_S i'_S}) \\ \partial_1^- T(\gamma_{RS}, \mathcal{Q}, \mathcal{Q}') = \psi(\gamma(0)_{i_R i_S i'_R i'_S}), & \partial_1^+ T(\gamma_{RS}, \mathcal{Q}, \mathcal{Q}') = \psi(\gamma(1)_{i_R i_S i'_R i'_S}) \end{cases}$$

Finally, to each $p_{RSTU} = \partial_2^+ \partial_1^+ \Gamma_R = \partial_2^+ \partial_1^- \Gamma_S = \partial_2^- \partial_1^+ \Gamma_T = \partial_2^- \partial_1^- \Gamma_U$, we assign the flat cube of Definition 3.1 (2) with open set indices i_R, i_S, i_T, i_U and i'_R, i'_S, i'_T, i'_U . The result follows from the fact that the set of flat 3-cubes in \mathcal{G} can be turned into a strict triple groupoid; see 2.2.2. ■

As an immediate consequence we have the following non-trivial result:

Corollary 5.5 *Let $\Gamma, \mathcal{Q}, \mathcal{Q}'$ be as in Theorem 5.4. If the open set assignments i_R and i'_R agree on the rectangles along the boundary of $[0, 1]^2$, then $\mathcal{H}(\Gamma, \mathcal{Q}) = \mathcal{H}(\Gamma, \mathcal{Q}')$.*

Proof. If we use condition 4 of Definition 3.1 and condition 1 of Definition 3.4 in equation (5.1) we can see that $T \circ \delta_i^\pm$ each are identity 2-cubes in \mathcal{G} for $i = 1, 2$. Now compare with the homotopy addition equation (2.4). ■

Analogously it follows:

Corollary 5.6 *Let $\Gamma, \mathcal{Q}, \mathcal{Q}'$ be as in Theorem 5.4. Suppose $\Gamma(\partial[0, 1]^2) = x$, for some $x \in M$, and that the open set assignments for all rectangles along the boundary of $[0, 1]^2$ are chosen to be the same, i.e. all equal to i_x for \mathcal{Q} and all equal to i'_x for \mathcal{Q}' . Then we have:*

$$\mathcal{H}(\Gamma, \mathcal{Q}) = (\phi_{i_x i'_x}(x))^{-1} \triangleright \mathcal{H}(\Gamma, \mathcal{Q}').$$

5.1.5 Invariance under (free) thin homotopy

Let M be a manifold with a local connection pair (A, B) . It follows from Theorem 4.5 that the two dimensional holonomy $\overset{(A, B)}{\mathcal{H}}(\Gamma)$, where $\Gamma: [0, 1]^2 \rightarrow M$ is a smooth path, is invariant under thin homotopy. Now suppose that M is equipped with a cubical \mathcal{G} -2-bundle connection. In this subsection we will study how $\mathcal{H}(\Gamma)$ varies under thin homotopy. We will consider a slightly more general definition of thin homotopy (a generality that is needed to define Wilson spheres).

Definition 5.7 *Two smooth maps $\Gamma, \Gamma': [0, 1]^2 \rightarrow M$ are said to be freely thin homotopic if there exists a smooth map $J: [0, 1]^2 \times [0, 1] \rightarrow M$ such that $\text{Rank}(\mathcal{D}_v J) \leq 2$, for each $v \in [0, 1]^3$, and such that $\partial_3^- J = \Gamma$ and $\partial_3^+ J = \Gamma'$.*

Note that J is, in general, not a rank-2 homotopy since it does not satisfy the conditions 1 and 2 of its definition; see 2.3.2.

Theorem 5.8 (Invariance under free thin homotopy) *Consider a free thin homotopy $J : [0, 1]^3 \rightarrow M$ with $\partial_3^- J = \Gamma$ and $\partial_3^+ J = \Gamma'$. Let \mathcal{Q} denote a subdivision of $[0, 1]^3$ into rectangular solids $\{Q_R\}_{R \in \mathcal{R}}$, using partitions of the three $[0, 1]$ factors, together with an assignment for each $R \in \mathcal{R}$ of $i_R \in \mathbb{J}$ such that $J(Q_R) \subset U_{i_R}$. Such subdivisions exist because of the Lebesgue Covering Lemma. Then \mathcal{Q} naturally induces subdivisions and open set assignments on each face of $[0, 1]^3$, denoted $\partial_i^\pm \mathcal{Q}$, $i = 1, 2, 3$.*

Then the holonomies $\mathcal{H}(\Gamma, \partial_3^- \mathcal{Q})$ and $\mathcal{H}(\Gamma', \partial_3^+ \mathcal{Q})$, with respect to a fixed cubical \mathcal{G} -2-bundle with connection \mathcal{B} , are related by the homotopy addition equation (2.4) for $T(J, \mathcal{Q})$, where:

$$\partial_i^\pm T(J, \mathcal{Q}) = \mathcal{H}(\partial_i^\pm J, \partial_i^\pm \mathcal{Q}), \quad i = 1, 2, 3.$$

Proof. The proof is very similar to the proof of Theorem 5.4. By analogy with the definition of holonomy, we reparametrize J to introduce additional 3-paths for each face separating the rectangular solids, for each edge separating these faces and for each point separating these edges. The additional 3-paths are constant in one, two or all three of the directions (horizontal, vertical, upwards). The cube $T(J, \mathcal{Q})$ is the composition of flat cubes of various types which, for the most part, we have already encountered in the proof of Theorem 5.4, or are analogous versions of these obtained by rotation. The remaining flat cubes are of the type appearing in Theorem 4.5, corresponding to J_R , the restriction of J to Q_R , reparametrized to be a 3-path, with the local connection pair (A_{i_R}, B_{i_R}) , for each $R \in \mathcal{R}$. Note that the curvature 3-form vanishes, since J is thin. ■

The following analogue of Corollary 5.6 holds.

Corollary 5.9 *Under the conditions of Theorem 5.8, suppose J is such that $J(\partial[0, 1]^2 \times \{t\}) = q(t)$, for some smooth map $q: [0, 1] \rightarrow M$, with $q(0) = x$ and $q(1) = x'$. Suppose also that the open set assignments for the rectangular solids along $\partial[0, 1]^2 \times [0, 1]$ only depend on the upwards direction, i.e. they are given by fixing $\partial_1^- \partial_2^- \mathcal{Q}$. Then*

$$\mathcal{H}(\Gamma, \partial_3^+ \mathcal{Q}) = (\mathcal{H}(q, \partial_1^- \partial_2^- \mathcal{Q}))^{-1} \triangleright \mathcal{H}(\Gamma, \partial_3^- \mathcal{Q}),$$

where $\mathcal{H}(q, \partial_1^- \partial_2^- \mathcal{Q})$ is defined in Definition 5.3.

5.1.6 Dihedral symmetry for the holonomy of general squares

Suppose that \mathcal{B} is a dihedral cubical \mathcal{G} -2-bundle over (M, \mathcal{U}) , with a dihedral cubical connection (see definitions 3.3 and 3.5). Let (Γ, \mathcal{Q}) be as in Definition 5.1, and let r be some element of the dihedral group D_4 of the square. Then we define \mathcal{Q}^r to be the subdivision of $[0, 1]^2$ with open set assignments induced on $\Gamma \circ r^{-1}$ by \mathcal{Q} .

Theorem 5.10 *We have:*

$$\mathcal{H}(\Gamma \circ r^{-1}, \mathcal{Q}^r) = r(\mathcal{H}(\Gamma, \mathcal{Q})).$$

Proof. This follows from theorems 4.4 and 4.12 and the definition of a dihedral cubical \mathcal{G} -2-bundle with a dihedral connection; definitions 3.3 and 3.5. Note that the action of r in $\mathcal{D}^2(\mathcal{G})$ is a double-groupoid morphism (see 2.2.1), so that it is enough to check the equation for all the 2-paths appearing in the definition of $\mathcal{H}(\Gamma, \mathcal{Q})$ and the corresponding 2-cubes of $\mathcal{D}^2(\mathcal{G})$ - see Definition 5.1. ■

5.1.7 Dependence of the surface holonomy on the cubical \mathcal{G} -2-bundle with connection equivalence class

Let \mathcal{B} be a cubical \mathcal{G} -2-bundle with connection over (M, \mathcal{U}) , and recall from subsection 4.3 the cubical \mathcal{G} -2-bundle with connection $\mathcal{B}_{\mathcal{V}}$ obtained from \mathcal{B} and a subdivision \mathcal{V} of the cover \mathcal{U} . Consider the holonomy $\overset{\mathcal{B}}{\mathcal{H}}(\Gamma, \mathcal{Q})$ of Definition 5.1. Let $\mathcal{Q}_{\mathcal{V}}$ denote the same subdivision of $[0, 1]^2$ into rectangles $\{Q_R\}_{R \in \mathcal{R}}$ as \mathcal{Q} , with assignments $R \mapsto a_R$ such that $\Gamma(Q_R) \subset V_{a_R}$, where $a_R \in S_{i_R}$ (using the notation at the end of subsection 4.3). Then it is clear from Definition 5.1 and Proposition 5.2 that we have:

$$\overset{\mathcal{B}_{\mathcal{V}}}{\mathcal{H}}(\Gamma, \mathcal{Q}_{\mathcal{V}}) = \overset{\mathcal{B}}{\mathcal{H}}(\Gamma, \mathcal{Q}).$$

Thus we will only consider equivalences of cubical \mathcal{G} -2-bundles with connection with respect to a fixed cover \mathcal{U} of M .

Suppose that \mathcal{B} and \mathcal{B}' are equivalent cubical \mathcal{G} -2-bundles with connection, with the equivalence given by the triple $(\Phi_i, \mathcal{E}_i, \Psi_{ij})$ of subsection 4.3.2. Note that condition (1) of the equivalence, in view of equation (4.3), may be rewritten as the following equations:

$$\begin{aligned} (A'_i, B'_i) &= (A_i, B_i) \triangleleft (\Phi_i, \mathcal{E}_i) & (A'_j, B'_j) &= (A'_i, B'_i) \triangleleft (\phi'_{ij}, \eta'_{ij}) \\ (A_j, B_j) &= (A_i, B_i) \triangleleft (\phi_{ij}, \eta_{ij}) & (A'_j, B'_j) &= (A_j, B_j) \triangleleft (\Phi_j, \mathcal{E}_j) \end{aligned}$$

We now proceed analogously to equation (5.1). Let γ be a 1-path, and let \mathcal{Q} be a subdivision of $[0, 1]$ into subintervals $\{q_r\}_{r=1, \dots, s}$, with an assignment $r \mapsto i_r \in \mathcal{I}$, such that $\gamma(q_r) \subset U_{i_r}$. Let γ_r denote the restriction of γ to q_r , rescaled and reparametrized to be a 1-path, and denote the points separating the images of γ_r by x_r . We define:

$$\overset{(\mathcal{B}, \mathcal{B}')}{s}(\gamma, \mathcal{Q}) \doteq \tau_{A_{i_1}}^{(\Phi_{i_1}, \mathcal{E}_{i_1})}(\gamma_1)(\Psi, \Phi)_{i_1 i_2}(x_1) \tau_{A_{i_2}}^{(\Phi_{i_2}, \mathcal{E}_{i_2})}(\gamma_2)(\Psi, \Phi)_{i_2 i_3}(x_2) \dots \tau_{A_{i_s}}^{(\Phi_{i_s}, \mathcal{E}_{i_s})}(\gamma_s). \quad (5.2)$$

Then the proof of Theorem 5.4 can be reformulated to give the dependence of the holonomy on changing \mathcal{B} within the same equivalence class.

Theorem 5.11 (Behaviour under cubical \mathcal{G} -2-bundle equivalences) *Let \mathcal{B} and \mathcal{B}' be equivalent cubical \mathcal{G} -2-bundles with connection, with the equivalence given by the triple $(\Phi_i, \mathcal{E}_i, \Psi_{ij})$. Let $\Gamma: [0, 1]^2 \rightarrow M$ be a smooth map and suppose \mathcal{Q} is a subdivision of $[0, 1]^2$ into rectangles $\mathcal{Q} = \{Q_R\}_{R \in \mathcal{R}}$, together with assignments $R \mapsto i_R$ such that $\Gamma(Q_R) \subset U_{i_R}$. Then the holonomies of (Γ, \mathcal{Q})*

with respect to \mathcal{B} and \mathcal{B}' are related by the homotopy addition equation (2.4) for $T \in D^3$, where T is given by:

$$T \circ \delta_3^- = \overset{\mathcal{B}}{\mathcal{H}}(\Gamma, \mathcal{Q}) \text{ and } T \circ \delta_3^+ = \overset{\mathcal{B}'}{\mathcal{H}}(\Gamma, \mathcal{Q})$$

and

$$T \circ \delta_i^\pm = \overset{(\mathcal{B}, \mathcal{B}')}{s}(\partial_i^\pm(\Gamma), \partial_i^\pm \mathcal{Q}).$$

We have the following analogue of Corollary 5.6.

Corollary 5.12 *Given the conditions of Theorem 5.11, suppose $\Gamma(\partial[0, 1]^2) = x$, for some $x \in M$, and that the open set assignments for all rectangles along the boundary of $[0, 1]^2$ are chosen to be the same, say i_x . Then*

$$\overset{\mathcal{B}'}{\mathcal{H}}(\Gamma, \mathcal{Q}) = (\Phi_{i_x}(x))^{-1} \triangleright \overset{\mathcal{B}}{\mathcal{H}}(\Gamma, \mathcal{Q}).$$

5.2 Two types of Wilson surfaces

Let \mathcal{B} be a cubical \mathcal{G} -2-bundle with connection over (M, \mathcal{U}) . Let $\Gamma: [0, 1]^2 \rightarrow M$ be a 2-path such that $\Gamma(\partial[0, 1]^2) = x$ for some $x \in M$. Thus Γ factors through a map $f: S^2 \rightarrow M$. We say that Γ and Γ' are equivalent if the corresponding maps f and f' from S^2 to M are related by $f' = f \circ g$ where g is an orientation-preserving diffeomorphism of S^2 .

Let \mathcal{Q} be a subdivision of $[0, 1]^2$ into rectangles $\{Q_R\}_{R \in \mathcal{R}}$ with open set assignments $R \mapsto i_R$ such that $\Gamma(Q_R) \subset U_{i_R}$, and suppose that these assignments are the same, say i_x , for all rectangles along the boundary of $[0, 1]^2$.

Definition 5.13 *With \mathcal{B} , Γ and \mathcal{Q} as above, we define the Wilson sphere functional to be*

$$\mathcal{W}_{\mathcal{B}}(\Gamma, \mathcal{Q}) = \overset{\mathcal{B}}{\mathcal{H}}(\Gamma, \mathcal{Q}) \in \ker \partial \subset E.$$

Theorem 5.14 *Up to acting by elements of G , the Wilson sphere functional $\mathcal{W}_{\mathcal{B}}(\Gamma, \mathcal{Q})$ is independent of the choice of \mathcal{Q} , the choice of Γ within the same equivalence class, and the choice of \mathcal{B} within the same equivalence class. For \mathcal{B} a dihedral bundle with dihedral connection and $r \in D_4$ an orientation reversing element, we have, following the notation of Theorem 5.10,*

$$\mathcal{W}_{\mathcal{B}}(\Gamma \circ r^{-1}, \mathcal{Q}^r) = (\mathcal{W}_{\mathcal{B}}(\Gamma, \mathcal{Q}))^{-1}.$$

Proof. The statement for \mathcal{Q} follows from subsection 5.1.2 and Corollary 5.6. Since the mapping class group of S^2 is $\{\pm 1\}$, when Γ and Γ' are equivalent, then they are isotopic. Thus there exists a thin free homotopy $J: [0, 1]^3 \rightarrow M$ of the type appearing in Corollary 5.9 (J is thin since it factors through a smooth family of diffeomorphisms of S^2), and satisfying $\partial_3^- J = \Gamma$ and $\partial_3^+ J = \Gamma'$. Thus the statement for Γ follows from Corollary 5.9. The statement for \mathcal{B} follows from Corollary 5.12. The final statement, when the bundle and connection are dihedral, is an immediate consequence of Theorem 5.10. ■

If the image of Γ is an embedded sphere Σ in M , then any two orientation-preserving parametrizations of Σ are equivalent. In this case we may state the result as follows:

Theorem 5.15 (Embedded Wilson Spheres) *The holonomy of an oriented embedded sphere Σ does not depend on the chosen parametrization of Σ up to acting by elements of G . We denote it by $\mathcal{W}_{\mathcal{B}}(\Sigma)$.*

This may have applications in 2-knot theory, c.f. [W, CR].

With \mathcal{B} as before, suppose now that Γ is such that $\partial_u\Gamma = \partial_d\Gamma$ and $\partial_l\Gamma = \partial_r\Gamma$. Then the 2-path Γ factors through a map f from the torus T^2 to M . We say that Γ and Γ' are equivalent if the corresponding maps f and f' from T^2 to M are related by $f' = f \circ g$ where g is an automorphism of T^2 which is isotopic to the identity (note that the mapping class group of the torus is $\text{GL}(2, \mathbb{Z})$).

Let \mathcal{Q} be a subdivision of $[0, 1]^2$ into rectangles $\{Q_R\}_{R \in \mathcal{R}}$ with open set assignments $R \mapsto i_R$ such that $\Gamma(Q_R) \subset U_{i_R}$, and suppose that these assignments are such that they match along the upper and lower boundary of $[0, 1]^2$, and along the left and right boundary of $[0, 1]^2$, i.e. $\partial_u\mathcal{Q} = \partial_d\mathcal{Q}$ and $\partial_l\mathcal{Q} = \partial_r\mathcal{Q}$.

Definition 5.16 *With \mathcal{B} , Γ and \mathcal{Q} as above, we define the Wilson torus functional to be*

$$\mathcal{W}_{\mathcal{B}}(\Gamma, \mathcal{Q}) = \overset{\mathcal{B}}{\mathcal{H}}(\Gamma, \mathcal{Q}) \in \partial^{-1}(G^{(1)}) \subset E,$$

where $G^{(1)}$ is the commutator subgroup of G .

Note that the value of the Wilson torus functional indeed belongs to $\partial^{-1}(G^{(1)})$, since

$$\partial(\overset{\mathcal{B}}{\mathcal{H}}(\Gamma, \mathcal{Q})) = [\overset{\mathcal{B}}{\mathcal{H}}(\partial_d\Gamma, \partial_d\mathcal{Q}), \overset{\mathcal{B}}{\mathcal{H}}(\partial_r\Gamma, \partial_r\mathcal{Q})].$$

Analogous arguments to the proof of Theorem 5.14, now using Theorem 5.4, Theorem 5.8 and Theorem 5.11, give:

Theorem 5.17 *The Wilson torus functional $\mathcal{W}_{\mathcal{B}}(\Gamma, \mathcal{Q})$ is independent of the choice of \mathcal{Q} , the choice of Γ within the same equivalence class, and the choice of \mathcal{B} within the same equivalence class, up to changes of the form of the following simultaneous horizontal and vertical conjugation:*

$$\mathcal{W}_{\mathcal{B}}(\Gamma, \mathcal{Q}) \mapsto \begin{array}{ccc} \ulcorner & e_2^{-v} & \urcorner \\ e_1 & \mathcal{W}_{\mathcal{B}}(\Gamma, \mathcal{Q}) & e_1^{-h} \\ \llcorner & e_2 & \lrcorner \end{array} .$$

Remark 5.18 *If the image of Γ is an embedded torus Σ in M , then unlike in the case of the sphere, the holonomy of Σ will in general depend on the mapping class of Γ and not just on the oriented embedded surface itself. This is a consequence of the fact that the mapping class group of the torus is $\text{GL}(2, \mathbb{Z})$ rather than $\{\pm 1\}$, which is the case of the sphere.*

Acknowledgements

The first author was supported by “Centro de Matemática e Aplicações da Universidade Nova de Lisboa”, through financiamento Base 2009 ISFL-1-297 from FCT/MCTES/PT.

This work was partially supported by the *Programa Operacional Ciência e Inovação 2010*, financed by FCT and cofinanced by the European Community fund FEDER, in part through the research projects PPCDT/MAT/60352/2004, PTDC/MAT/101503/2008 and PTDC/MAT/098770/2008.

We would like to thank Jim Stasheff and Tim Porter for useful comments.

References

- [AF] Altschuler D.; Freidel L.: Vassiliev knot invariants and Chern-Simons perturbation theory to all orders. *Comm. Math. Phys.* 187 (1997), no. 2, 261–287.
- [ACG] Aschieri P.; Cantini L.; Jurčo B.: Nonabelian bundle gerbes, their differential geometry and gauge theory. *Comm. Math. Phys.* 254 (2005), no. 2, 367–400
- [B] Baez J.C.: Higher Yang-Mills Theory, arXiv:hep-th/0206130.
- [BC] Baez J.C.; Crans A.S.: Higher-dimensional algebra. VI. Lie 2-algebras. *Theory Appl. Categ.* 12 (2004), 492–538 (electronic)
- [BHo] Baez J. C.; Hoffnung A.E.: Convenient categories of smooth spaces. arXiv:0807.1704v2 [math.DG]. To appear in *Trans AMS*.
- [BL] Baez J.C.; Lauda A.D.: Higher-dimensional algebra. V. 2-groups. *Theory Appl. Categ.* 12 (2004), 423–491 (electronic)
- [BS1] Baez J.C.; Schreiber U.: Higher Gauge Theory: 2-Connections on 2-Bundles. arXiv:hep-th/0412325
- [BS2] Baez J.C.; Schreiber U.: Higher Gauge Theory. arXiv:math/0511710.
- [BM] Barrett J.W.; Mackaay M.: Categorical representations of categorical groups. *Theory Appl. Categ.* 16 (2006), No. 20, 529–557 (electronic).
- [Bar] Bartels T.: Higher gauge theory I: 2-Bundles. arXiv:math/0410328v3 [math.CT].
- [BrMe] Breen L.; Messing W.: Differential geometry of gerbes. *Adv. Math.* 198 (2005), no. 2, 732–846.
- [B1] Brown R.: Groupoids and crossed objects in algebraic topology. *Homology Homotopy Appl.* 1 (1999), 1–78

- [BHKP] Brown R.; Hardie K. A.; Kamps K. H.; Porter T.: A homotopy double groupoid of a Hausdorff space. *Theory Appl. Categ.* 10 (2002), 71–93 (electronic).
- [BH1] Brown R., Higgins P.J.: On the connection between the second relative homotopy groups of some related spaces. *Proc. London Math. Soc.* (3) 36 (1978), no. 2, 193–212.
- [BH2] Brown R., Higgins P.J.: Colimit Theorems for Relative Homotopy Groups, *J. Pure Appl. Algebra* 22 (1981), no. 1, 11–41.
- [BH3] Brown R., Higgins P.J.: On the Algebra of Cubes, *J. Pure Appl. Algebra* 21 (1981), no. 3, 233–260.
- [BH4] Brown R., Higgins P.J.: Tensor Products and Homotopies for ω -Groupoids and Crossed Complexes, *J. Pure Appl. Algebra* 47 (1987), no. 1, 1–33.
- [BH5] Brown R., Higgins P.J.: The Classifying Space of a Crossed Complex, *Math. Proc. Cambridge Philos. Soc.* 110 (1991), no. 1, 95–120.
- [BH6] Brown R.; Higgins; P.J: The equivalence of ∞ -groupoids and crossed complexes. *Cahiers Topologie Géom. Différentielle* 22 (1981), no. 4, 371–386.
- [BHS] Brown R., Higgins P.J., Sivera R.: Nonabelian algebraic topology, (in preparation). Part I downloadable.
- [BS] Brown R.; Spencer, C.B.: Double groupoids and crossed modules. *Cahiers Topologie Géom. Différentielle* 17 (1976), no. 4, 343–362.
- [CP] Caetano A.; Picken R. F.: An axiomatic definition of holonomy. *Internat. J. Math.* 5 (1994), no. 6, 815–848.
- [CR] Cattaneo A.S.; Rossi C.A.: Wilson surfaces and higher dimensional knot invariants. *Comm. Math. Phys.* 256 (2005), no. 3, 513–537.
- [Ch] Chen, Kuo-tsai: Iterated integrals of differential forms and loop space homology. *Ann. of Math.* (2) 97 (1973), 217–246.
- [FM] Faria Martins J.: The fundamental crossed module of the complement of a knotted surface, to appear in *Trans AMS*. arXiv:0801.3921v1 [math.GT].
- [FMP1] Faria Martins J.; Picken R.: On two-dimensional holonomy, to appear in *Trans AMS*. arXiv:0710.4310v2 [math.DG].
- [FMP2] Faria Martins J.; Picken R.: The fundamental Gray 3-groupoid of a smooth manifold and local 3-dimensional holonomy based on a 2-crossed module, arXiv:0907.2566v3 [math.CT].

- [FMPo] Faria Martins J.; Porter T.: On Yetter’s invariant and an extension of the Dijkgraaf-Witten invariant to categorical groups. *Theory Appl. Categ.* 18 (2007), No. 4, 118–150 (electronic).
- [GM] Grandis M.; Mauri L.: Cubical sets and their site, *Theory and Applications of Categories* , Vol. 11, 2003, No. 8, pp 185-211.
- [HKK] Hardie K. A.; Kamps K. H.; Kieboom R. W.: A Homotopy 2-Groupoid of a Hausdorff Space. *Papers in honour of Bernhard Banaschewski* (Cape Town, 1996). *Appl. Categ. Structures* 8 (2000), no. 1-2, 209–214.
- [Hi] Higgins, Philip J.: Thin elements and commutative shells in cubical ω -categories. *Theory Appl. Categ.* 14 (2005), No. 4, 60–74 (electronic).
- [H] Hitchin N.: Lectures on special Lagrangian submanifolds. *Winter School on Mirror Symmetry, Vector Bundles and Lagrangian Submanifolds* (Cambridge, MA, 1999), 151–182, *AMS/IP Stud. Adv. Math.*, 23, Amer. Math. Soc., Providence, RI, 2001.
- [J1] Jardine J.F.: *Categorical homotopy theory, Homology, Homotopy and Applications*, Vol. 8 (2006), No. 1, pp.71-144.
- [K] Knapp A.W.: *Lie groups beyond an introduction*. *Progress in Mathematics*, 140. Birkhäuser Boston, Inc., Boston, MA, 1996.
- [Ko] Kontsevich M.: Vassiliev’s knot invariants. I. *M. Gel’fand Seminar*, 137–150, *Adv. Soviet Math.*, 16, Part 2, Amer. Math. Soc., Providence, RI, 1993.
- [MP] Mackaay M.; Picken R.F.: Holonomy and parallel transport for abelian gerbes. *Adv. Math.* 170 (2002), no. 2, 287-219.
- [M] Mackaay M.: A note on the holonomy of connections in twisted bundles. *Cah. Topol. Géom. Différ. Catég.* 44 (2003), no. 1, 39–62.
- [Ma] May J.P.: *Simplicial objects in algebraic topology*. Reprint of the 1967 original. *Chicago Lectures in Mathematics*. University of Chicago Press, Chicago, IL, 1992.
- [P] Picken R.F.; TQFT and gerbes, *Algebraic and Geometric Topology*, 4 (2004) 243–272
- [RS] Roberts D.M.; Schreiber U.: The inner automorphism 3-group of a strict 2-group, *Journal of Homotopy and Related Structures*, Vol. 3(2008), No. 1, pp. 193-244. arXiv:0708.1741v2 [math.CT].
- [SW1] Schreiber U.; Waldorf K.: Parallel Transport and Functors, arXiv:0705.0452v2 [math.DG].

- [SW2] Schreiber U.; Waldorf K.: Smooth Functors vs. Differential Forms, arXiv:0802.0663v1 [math.DG].
- [SW3] Schreiber U.; Waldorf K.: Connections on non-abelian gerbes and their holonomy, arXiv:0808.1923v1 [math.DG].
- [W] Witten E.: Quantum field theory and the Jones polynomial. *Comm. Math. Phys.* 121 (1989), no. 3, 351–399.
- [Wo] Wockel C.: A global perspective to gerbes and their gauge stacks. arXiv:0803.3692v3 [math.DG].